

YASKAWA AC Drive V1000 Option

ETHERNET 

POWERLINK

Technical Manual

Type: SI-EL3/V for V1000 Series

To properly use the product, read this manual thoroughly and retain for easy reference, inspection, and maintenance. Ensure the end user receives this manual.

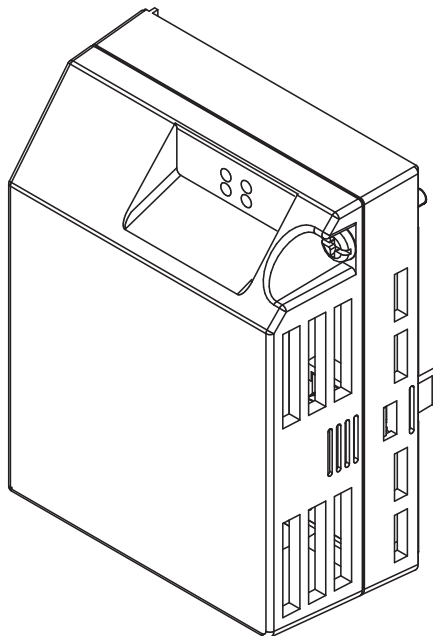

ATTENTION!

This product can only be used on V1000 drives with firmware version VSV901022 to VSV901099 installed.

MANUAL NO. YEU SIEP C710606 84A



RoHS Directive
RoHS Directive Stands for
the EU directive on the
Restriction of the Use of
Certain Hazardous
Substances in Electrical
and Electronic Equipment.

Table of Contents

1 PREFACE AND SAFETY	4
2 PRODUCT OVERVIEW	6
3 RECEIVING	7
4 POWERLINK OPTION COMPONENTS	8
5 INSTALLATION PROCEDURE	10
6 POWERLINK OPTION RELATED DRIVE PARAMETERS	14
7 DSP301 AND DSP402 SPECIFICATIONS	15
8 OBJECT DICTIONARY	19
9 CONFIGURING MANUFACTURER SPECIFIC CANOPEN OBJECTS	33
10 PROCESS DATA OBJECTS (PDO)	34
11 DRIVE PARAMETER, MONITOR AND CONTROL REGISTER ACCESS	36
12 FAULT DIAGNOSIS AND POSSIBLE SOLUTIONS	37
13 SPECIFICATIONS	40

Copyright © 2013 YASKAWA EUROPE GMBH

All rights reserved. No part of this publication may be reproduced, stored in a retrieval system, or transmitted, in any form or by any means, mechanical, electronic, photocopying, recording, or otherwise, without the prior written permission of YASKAWA. No patent liability is assumed with respect to the use of the information contained herein. Moreover, because YASKAWA is constantly striving to improve its high-quality products, the information contained in this manual is subject to change without notice. Every precaution has been taken in the preparation of this manual. YASKAWA assumes no responsibility for errors or omissions. Neither is any liability assumed for damages resulting from the use of the information contained in this publication.

1 Preface and Safety

YASKAWA manufactures products used as components in a wide variety of industrial systems and equipment. The selection and application of YASKAWA products remain the responsibility of the equipment manufacturer or end user. YASKAWA accepts no responsibility for the way its products are incorporated into the final system design. Under no circumstances should any YASKAWA product be incorporated into any product or design as the exclusive or sole safety control. Without exception, all controls should be designed to detect faults dynamically and fail safely under all circumstances. All systems or equipment designed to incorporate a product manufactured by YASKAWA must be supplied to the end user with appropriate warnings and instructions as to the safe use and operation of that part. Any warnings provided by YASKAWA must be promptly provided to the end user. YASKAWA offers an express warranty only as to the quality of its products in conforming to standards and specifications published in the YASKAWA manual. **NO OTHER WARRANTY, EXPRESS OR IMPLIED, IS OFFERED.** YASKAWA assumes no liability for any personal injury, property damage, losses, or claims arising from misapplication of its products.

◆ Applicable Documentation

The following manuals are available for SI-EL3/V Powerlink Option card:

Option Card

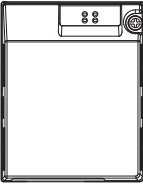
	YASKAWA AC Drive V1000 Option Powerlink Installation Manual Manual No.: YEU TOEP C710606 85A
	Read this manual first. The installation manual is packaged with the Powerlink Option and contains a basic overview of wiring, settings, functions, and fault diagnoses.
	YASKAWA AC Drive V1000 Option Powerlink Technical Manual (this book) Manual No.: YEU SIEP C710606 84A
	The technical manual contains detailed information. To obtain the technical manual access these sites: Europe: http://www.yaskawa.eu.com Other areas: contact a YASKAWA representative.

For the drive setup, refer to one of the documentation listed below.

YASKAWA Drive

	Refer to the manual of the drive this option card is being used with. The instruction manual for the drive covers basic installation, wiring, operation procedures, functions, troubleshooting, and maintenance information. It also includes important information on parameter settings and how to tune the drive. A Quick Start Guide is included with the drive. For the more detailed technical manual, visit YASKAWA's home page. Europe: http://www.yaskawa.eu.com Other areas: contact a YASKAWA representative
--	---

◆ Terms

Note: Indicates supplemental information that YASKAWA highly recommends be followed. Content identified by Note: is not related to personnel safety or equipment damage safety messages.

- Powerlink Option:** YASKAWA AC Drive SI-EL3/V Powerlink option card
- Powerlink:** Standard for CANopen over Ethernet according to the Ethernet POWERLINK Standardization Group
- EPL:** Ethernet Powerlink
- Host:** YASKAWA inverter 1000 series
- LED:** Light Emitting Diode
- OPT, Option:** The unit described in this document
- FCS:** Frame Check Sequence
- INVR:** Inverter register number
- EPSPG:** Ethernet Powerlink Standardization Group
- NMT:** Network management
- MN:** Powerlink managing node
- CN:** Powerlink controlled node
- RFG:** Ramp function generators

◆ Registered Trademarks

- Company names and product names listed in this manual are registered trademarks of those companies.

◆ Supplemental Safety Information

Read and understand this manual before installing, operating, or servicing this option card. The option card must be installed according to this manual and local codes.

The following conventions are used to indicate safety messages in this manual. Failure to heed these messages could result in serious or possibly even fatal injury or damage to the products or to related equipment and systems.

DANGER

Indicates a hazardous situation, which, if not avoided, will result in death or serious injury.

WARNING

Indicates a hazardous situation, which, if not avoided, could result in death or serious injury.

CAUTION

Indicates a hazardous situation, which, if not avoided, could result in minor or moderate injury.

NOTICE

Indicates an equipment damage message.

■ General Safety

General Precautions

- The diagrams in this section may include drives without covers or safety shields to illustrate details. Be sure to reinstall covers or shields before operating any devices. The option board should be used according to the instructions described in this manual.
- Any illustrations, photographs, or examples used in this manual are provided as examples only and may not apply to all products to which this manual is applicable.
- The products and specifications described in this manual or the content and presentation of the manual may be changed without notice to improve the product and/or the manual.
- When ordering a new copy of the manual due to damage or loss, contact your YASKAWA representative or the nearest YASKAWA sales office and provide the manual number shown on the front cover.

DANGER

Heed the safety messages in this manual.

Failure to comply will result in death or serious injury.

The operating company is responsible for any injuries or equipment damage resulting from failure to heed the warnings in this manual.

NOTICE

Do not expose the drive to halogen group disinfectants.

Failure to comply may cause damage to the electrical components in the option card.

Do not pack the drive in wooden materials that have been fumigated or sterilized.

Do not sterilize the entire package after the product is packed.

Do not modify the drive circuitry.

Failure to comply could result in damage to the drive and will void warranty.

YASKAWA is not responsible for any modification of the product made by the user. This product must not be modified.

2 Product Overview

◆ About This Product

The Powerlink Option (Model: SI-EL3/V) is an option card designed to connect the YASKAWA AC drive to a Powerlink network. Using this option card a Powerlink master can:

- operate the drive
- monitor the drive operation status
- read or modify drive parameters.

The SI-EL3/V option provides instant connectivity to a Powerlink network for the YASKAWA V1000 drive. The option contains support for the Velocity mode according the CANopen Device Profile and Motion Control (DSP402) profile. It also contains YASKAWA vendor specific CANopen objects based on the present CANopen option board specification.

The Powerlink Option supports the following communication profiles:

- DS 301 Ver. 4.02
- DSP 402 Ver. 3.0 Velocity Mode

◆ Applicable Models

The option can be used with the drive models in [Table 1](#).

Table 1 Applicable Models

Drive Series	Drive Model Number	Software Version <1>
V1000	CIMR-V□2□□□□□	VSV901022 to VSV901099
	CIMR-V□4□□□□□	
	CIMR-V□B□□□□□	

<1> See “PRG” on the drive nameplate for the software version number.



3 Receiving

Please perform the following tasks after receiving the Powerlink Option:

- Inspect the Powerlink Option for damage.
If the Powerlink Option appears damaged upon receipt, contact the shipper immediately.
- Verify receipt of the correct model by checking the information on the PCB (see *Figure 1*).
- If you have received the wrong model or the Powerlink Option does not function properly, contact your supplier.

◆ Contents and Packaging

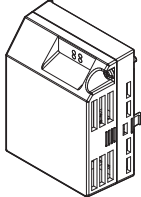
Table 2 Option Package Contents

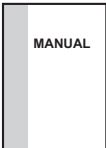
Description:	Option Card	Ground Cable	Installation Manual
			
Quantity:	1	4	1

◆ Tool Requirements

A Phillips screwdriver PH1(#1) or PH2(#2) is required to install the Powerlink option.

Note: Tools required to prepare Powerlink cables for wiring are not listed in this manual.

4 Powerlink Option Components

◆ Powerlink Option

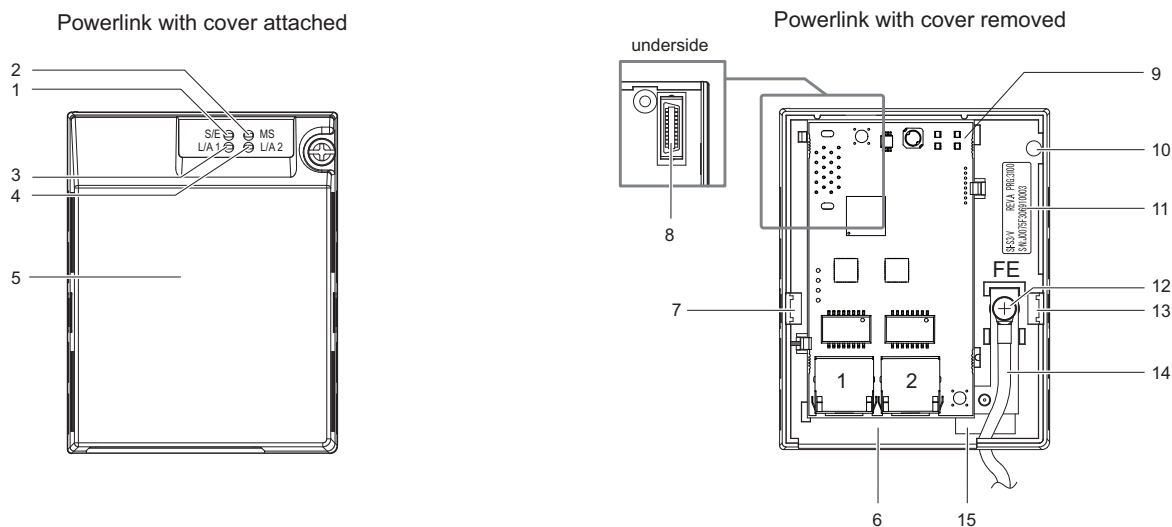

- 1 - LED (SE)
- 2 - LED (MS)
- 3 - LED (L/A 1)
- 4 - LED (L/A 2)
- 5 - Option Cover
- 6 - Communication cable connector (RJ45)
- 7 - Mounting clip
- 8 - Option board connector
- 9 - Powerlink PCB
- 10 - Attachment screw hole for option cover
- 11 - Nameplate
- 12 - Function Earth wire connection (FE)
- 13 - Mounting clip
- 14 - Wire
- 15 - Through-hole for wire

Figure 1 Option Card

For details on the LEDs, refer to *Powerlink Option Status LEDs on page 9*.

◆ Communication connector

The Powerlink Option is connected to the network using a RJ45 connector. The pin assignment is explained in *Table 3*.

Table 3 Communication connector (RJ45)

Powerlink Connector	Pin	Signal	Description
	1	TD+	Send data
	2	TD-	
	3	RD+	Receive data
	4	-	N.C. (Pins denoted as N.C. do not connect to any signal)
	5	-	N.C. (Pins denoted as N.C. do not connect to any signal)
	6	RD-	Receive data
	7	-	N.C. (Pins denoted as N.C. do not connect to any signal)
	8	-	N.C. (Pins denoted as N.C. do not connect to any signal)
Housing	-	-	Shield

◆ **Powerlink Option Status LEDs**

The Powerlink Option has four LEDs that indicate the communication status. The indications conform with DS303, Part 3: Indicator Specification.

■ **LEDs L/A 1 and L/A 2: Ethernet Link/Activity 1 and 2**

The Link/Activity indicators show the status of the physical link and show activity on the link period

■ **S/E LED**

A green lit Powerlink S/E LED indicates the status of the Powerlink network state machine.

A red lit Powerlink S/E LED indicates error on the EPL network side.

■ **MS LED**

The red Powerlink MS LED indicates the presence of any errors.

Table 4 UNDERSTANDING THE STATUS LEDs

LED	Color	Display	Meaning
Link Activity 1/2	-	Continuously Off	No link
	Green	Continuously On	The module is connected to Ethernet
		Flickering	There is traffic on Ethernet, data are being exchanged
S/E	-	Continuously Off	The device is in Init state
	Green	Flickering	The device is in NMT_CS_BASIC_ETHERNET state
		Blinking	The device is in NMT_CS_STOPPED state
		Single flash	The device is in NMT_CS_PRE_OPERATIONAL_1 state
		Double flash	The device is in NMT_CS_PRE_OPERATIONAL_2 state
		Triple flash	The device is in NMT_CS_READY_TO_OPERATE state
		Continuously On	The device is in NMT_CS_OPERATIONAL state
	Red	Off	Normal operation
		On	An error has occurred
	MS	Red	Off
On			Option card FATAL event has occurred (System has stalled execution. See Powerlink vendor object 0x4000 for the cause)

Figure 2 explains the indicator flash rates.

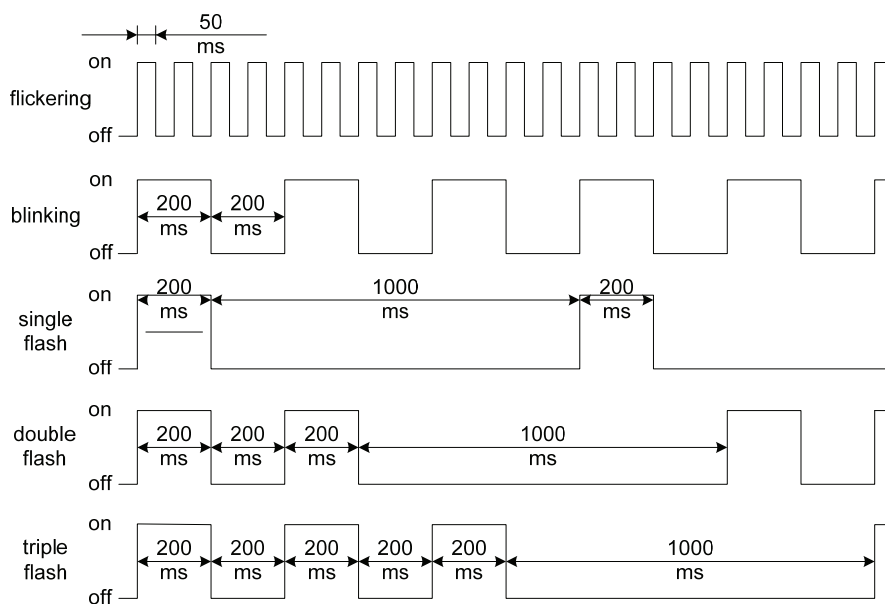

Figure 2 LED Flash Rates and Meaning

5 Installation Procedure

◆ Section Safety

DANGER

Electric Shock Hazard

Power to the drive must be shut off when installing this option card.

Even though the power has been shut off, voltage still remains in the drive's DC bus. Wait before removing the front cover once the drive has been turned off.

The CHARGE light on the drive will go out after voltage in the DC bus drops below 50 V, at which point it is safe to remove the front cover.

Due to the risk of electric shock, be sure that all LEDs have gone out and that the DC bus voltage has reached a safe level prior to performing any work on the drive.

WARNING

Electrical Shock Hazard

Do not remove the front cover of the drive while the power is on.

Failure to comply could result in death or serious injury.

The diagrams in this section may include drives without covers or safety shields to show details. Be sure to reinstall covers or shields before operating any devices. The option board should be used according to the instructions described in this manual.

Do not allow unqualified personnel to use equipment.

Failure to comply could result in death or serious injury.

Maintenance, inspection, and replacement of parts must be performed only by authorized personnel familiar with installation, adjustment, and maintenance of this product.

Do not touch the option card while the power supply to the drive is switched on.

Failure to comply could result in death or serious injury.

Do not use damaged wires, place excessive stress on wiring, or damage the wire insulation.

Failure to comply could result in death or serious injury.

NOTICE

Damage to Equipment

Observe proper electrostatic discharge procedures (ESD) when handling the option card, drive, and circuit boards.

Failure to comply may result in ESD damage to circuitry.

Never shut the power off while the drive is outputting voltage.

Failure to comply may cause the application to operate incorrectly or damage the drive.

Do not operate damaged equipment.

Failure to comply may cause further damage to the equipment.

Do not connect or operate any equipment with visible damage or missing parts.

Tighten all terminal screws to the specified tightening torque.

Loose electrical connections could result in death or serious injury by fire due to overheating of electrical connections.

Do not use unshielded cable for control wiring.

Failure to comply may cause electrical interference resulting in poor system performance.

Use shielded twisted-pair wires and ground the shield to the ground terminal of the drive.

Properly connect all pins and connectors.

Failure to comply may prevent proper operation and possibly damage equipment.

Check wiring to ensure that all connections are correct after installing the option card and connecting any other devices.

Failure to comply may result in damage to the option card.

◆ Prior to Installing the Option Card

Prior to installing the Powerlink Option, wire the drive and make necessary connections to the drive terminals. For more information on wiring and connecting the drive, refer to the manual packaged with the drive. Verify that the drive runs normally without the option installed.

◆ Installing the Option Unit

Remove the front cover of the drive before installing the Powerlink Option. Follow the directions below for proper installation.

1. Switch off the power supply to the drive.

DANGER! Electrical Shock Hazard - Do not connect or disconnect wiring while the power is on. Failure to comply will result in death or serious injury. Before installing the Powerlink Option, disconnect all power to the drive. The internal capacitor remains charged even after the power supply is turned off. The charge indicator LED will extinguish when the DC bus voltage is below 50 VDC. To prevent electric shock, wait at least five minutes after all indicators are off and measure the DC bus voltage level to confirm safe level.

2. Remove the front cover. The original drive front cover may be discarded because it will be replaced by the Powerlink Option cover in step 8.

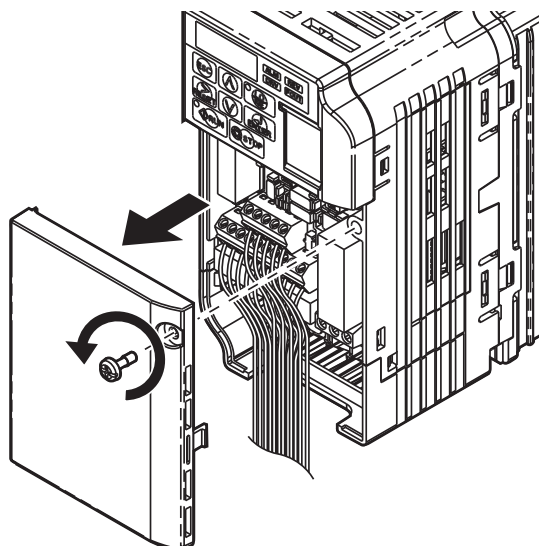

Figure 3 Remove Front Cover

3. Remove the bottom cover and connect the Powerlink Option ground wire to the ground terminal.

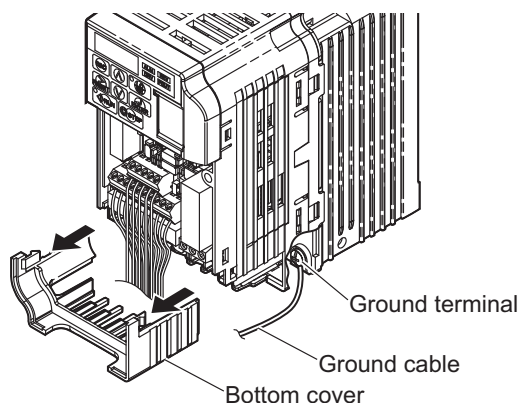

Figure 4 Connect Ground Wire

Note: The four different ground wires packaged with the Powerlink Option connect the unit to different drive models. Select the proper ground wire from the Powerlink Option kit depending on drive size. [Refer to Ground Wire Selection on page 12.](#)

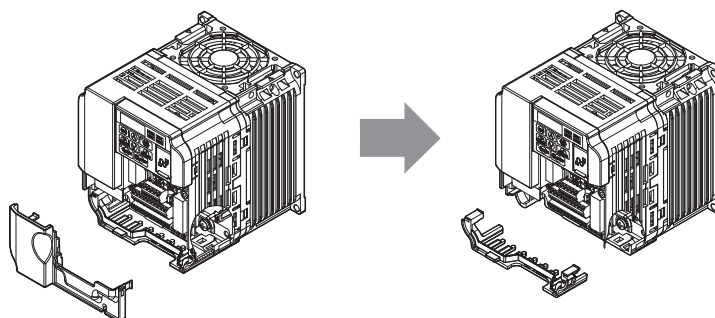
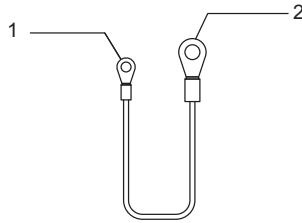

Figure 5 Models with Terminal Cover



- 1 – Option unit connection: screw size = M3
- 2 – Drive-side connection: screw size = M3.5 to M6

Figure 6 Ground Wire

Table 5 Ground Wire Selection

Ground Wire Length (mm/in)	Drive Model CIMR-V		
	Single-Phase 200 V Class	Three-Phase 200 V Class	Three-Phase 400 V Class
150/5.9	BA0001 BA0002 BA0003	2A0001 2A0002 2A0004 2A0006	-
200/7.9	BA0006 BA0010 BA0012 BA0018	2A0010 2A0012 2A0020	4A0001 4A0002 4A0004 4A0005 4A0007 4A0009 4A0011
250/9.8	-	2A0030 2A0040	4A0018 4A0023
400/15.7	-	2A0056 2A0069	4A0031 4A0038

Note: Cover removal steps for certain larger models of V1000 with a Terminal Cover:

- Single-Phase 200 V Class: CIMR-V□BA0006 to BA0018
- Three-Phase 200 V Class: CIMR-V□2A0008 to 2A0069
- Three-Phase 400 V Class: All models

Remove the terminal cover before removing the bottom cover to install the Powerlink Option. Replace the terminal cover after wiring the Powerlink Option.

4. Reattach the bottom cover.
5. Connect the Powerlink Option to the drive. Properly secure the tabs on the left and right sides of the Powerlink Option to the drive case.

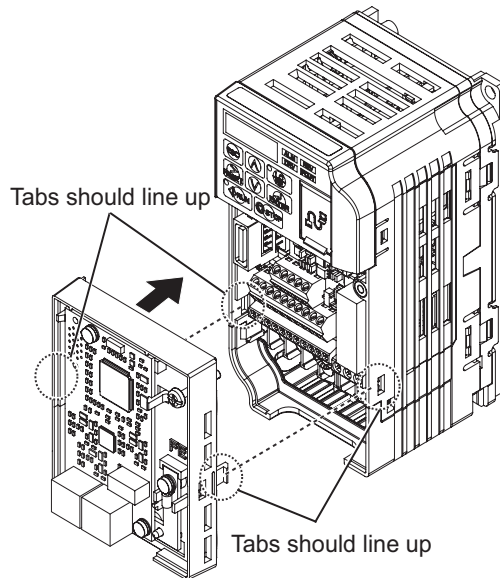

Figure 7 Attach Powerlink Option

- Connect the ground wire between the drive ground terminal and the Powerlink Option ground. When wiring the Powerlink Option, pass the ground wire through the inside of the drive bottom cover, then pass the ground wire into the through-hole for the ground wire at the front of the Powerlink Option.

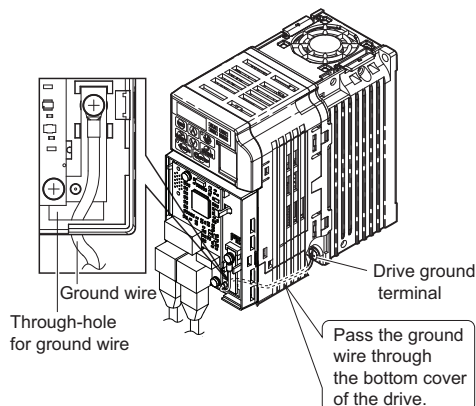

Figure 8 Ground Wire Connection

- Connect the communication wire to the Powerlink Option modular connector. The network can be established in star, tree, line or ring architecture.
- Attach the Powerlink Option cover to the front of the Powerlink Option.

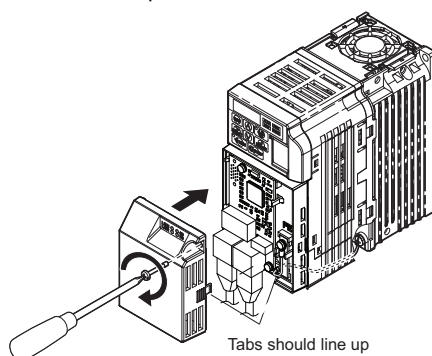

Figure 9 Attach Cover

◆ Communication Cable Specifications

To ensure proper performance, Yaskawa recommends using Powerlink dedicated Cat5e communication cables.

◆ Network Termination

The Powerlink network does not require a termination resistor if the drive is the last node in the network. Network termination is realized by the ASIC of the Powerlink option card.

◆ XDD File

For easy network implementation of drives equipped with an Powerlink Option, the XDD file can be obtained from:

Europe: <http://www.yaskawa.eu.com>

Other areas: contact a Yaskawa representative

◆ Identification of Drive Firmware Version

- Read out firmware version from drive digital operator. Check monitor parameter U1-25 when the drive is switched ON. The display shows the last four digits of the firmware version and the value should be in the range of 1022 ~ 1099.
- Verifying firmware version on drive nameplate

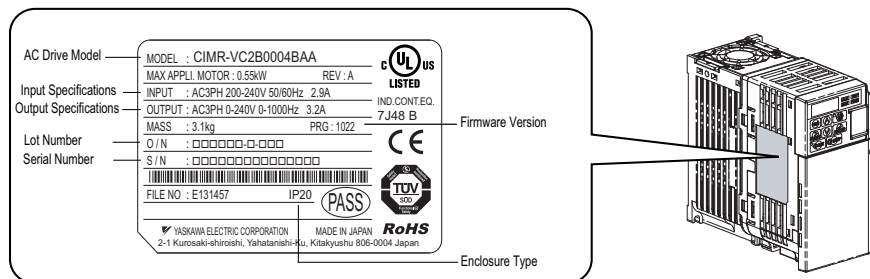

Figure 10 Verifying firmware version on drive nameplate

6 Powerlink Option Related Drive Parameters

The drive parameters listed in [Table 6](#) have influence on some functions of the SI-EL3/V option card. Check these parameters before starting network communications.

Table 6 Parameter Settings

No.	Name	Description	Default
b1-01 <1>	Frequency Reference Selection	Selects the frequency reference input source 0: Operator - Digital preset speed d1-01 to d1-17 1: Terminals - Analog input terminals 2: MEMOBUS/Modbus communications 3: Option card 4: Pulse Input (Terminal RP)	<6>
b1-02 <1>	Run Command Selection	Selects the run command input source 0: Digital Operator - RUN and STOP keys 1: Digital input terminals S□ 2: MEMOBUS/Modbus communications 3: Option card	1
E2-04 <2>	Motor 1 Motor Poles	Set the number of motor poles described on the motor nameplate. 2 to 48	4
F6-01	Operation Selection after Communications Error	Determines drive response when a BUS error is detected during communications with the Powerlink Option 0: Ramp to Stop 1: Coast to Stop 2: Fast-Stop 3: Alarm Only <3>	1
F6-02	External Fault Detection Conditions (EF0)	Sets the condition for external fault detection (EF0) 0: Always detected 1: Detected only during operation	0
F6-03	Stopping Method for External Fault from Communication Option Board	Determines drive response for external fault input (EF0) detection during Powerlink communication 0: Ramp to Stop 1: Coast to Stop 2: Fast-Stop 3: Alarm Only <3>	1
F6-06 <4>	Torque Reference/Torque Limit selection from Communications Option	0: Torque reference/torque limit via network communications are disabled. 1: Torque reference/torque limit via network communications are enabled. <5>	0
F6-07 <8>	NetRef/ComRef Selection Function	0: Multi-step speed reference disabled (F7 mode) 1: Multi-step speed reference allowed (V7 mode)	0
F6-08	Reset Communication Related Parameters	Determines if communication-related parameters are set back to their original default values when the drive is initialized. 0: Do not reset F6-□□ and F7-□□ parameters when the drive is initialized using parameter A1-03. 1: Rest F6-□□ and F7-□□ parameters when the drive is initialized using parameter A1-03. Note: Setting this parameter does not affect communication-related parameters. Setting this parameter only determines if communication-related parameters (F6-□□ and F7-□□) are also reset when A1-03 is used to initialize the drive.	0
F6-72	Powerlink Node ID	Sets the Node ID that is used to access the drive in a Powerlink network.	0
o1-03 <7>	Digital Operator Display Selection	Sets the units to display the frequency reference and output frequency. 0: 0.01 Hz 1: 0.01% (100% = E1-04) 2: r/min (enter the number of motor poles to E2-04/E4-04/E5-04) 3: User defined by parameters o1-10 and o1-11	<6>

<1> To start and stop the drive from an Powerlink master device using serial communications, set b1-02 to 3. To control the frequency reference of the drive via the master device, set b1-01 to 3.

<2> E2-04 is necessary to set up when the Drive Profile DSP402 objects are used.

<3> If set to 3, then the drive will continue to operate when an EF0 fault is detected. Take proper safety measures, such as installing an emergency stop switch.

<4> This parameter might not appear in certain drives. Furthermore its availability is limited depending on the control mode selection. For details refer to the Technical Manual for the drive the option card is used with.

<5> If the drive is set to receive the torque reference/limit from the network (F6-06 = 1) make sure the value is set appropriately by the controller. If no torque reference/limit value is entered the motor will not produce torque.

<6> For details refer to the Technical Manual for the drive the option card is used with.

<7> The default value depends on the drive used and/or the drive software version. For details refer to the technical manual for the drive.

<8> Changing o1-03 changes the units for input object 2010 (Hex) (frequency reference), output object 2110 (Hex) (output frequency) and 2200 (Hex) (motor speed). Confirm parameter o1-03 is set to 2 and parameter E2-04 is set to the correct value when using Drive Profile DSP402.

<9> For details refer to the Technical Manual for the drive the option card is used with.

7 DSP301 and DSP402 specifications

Network communication on Powerlink is based on the DSP301 communication profile and the CANopen DSP402 device profile for drives and motion control. This profile specifies mandatory objects that will be implemented as well as manufacturer specific and optional objects.

Process Data Objects (PDOs) are used for I/O exchange and Service Data Object (SDO) for explicit messaging. The time for transmitting PDOs is significantly lower than the time for transmitting SDO, therefore, communication objects like command/reference are mapped onto PDOs as standard.

All CANopen communication objects can be accessed via SDO. The SDO allow acknowledged access to communication objects, i.e., the communication adapter confirms the intended access.

7.1 Modes

The V1000 series Powerlink option supports two operating modes:

Table 7 States of the Powerlink State Machine

Mode	Description	Mode Verification
DSP402 Velocity mode	In this mode the drive can be controlled using standardised I/O objects. This simple mode allows to control the velocity of the drive with limits and ramp functions.	DSP402 object 0x6061 (Modes of operation display) = 2
Vendor specific mode (DSP402 profile bypass)	In this mode the DSP402 state machine processor in the option is bypassed and the drive native control/status words are used. Besides controlling the drive, this mode allows flexible access to drive parameters and monitors.	DSP402 object 0x6061 (Modes of operation display) = -2

Profile/vendor mode activation is done automatically by the option within the following constraints:

1. If an RxPDO mapping has been assigned to DSP402 control word 0x6040 and Powerlink is in the SAFEOP or OP state the DSP402 profile will be processed.
2. If the Powerlink state machine is NOT in the SAFEOP or OP state and an SDO write request is performed on the DSP402 0x6040 control word the DSP402 profile will be processed.
3. If the Powerlink state machine is NOT in the SAFEOP or OP state and an SDO read request is performed on the DSP402 0x6041 status word the DSP402 profile will be processed.
4. Otherwise the vendor specific control word will be accessed normally.

The numbers of poles has to be set correctly and the display unit of the inverter has to be switched to rpm for proper operation. Refer to [Table 6](#) for further details.

7.2 Implemented CANopen Objects/Components

The following message types are implemented:

- SDO (Service Data Object) uses asynchronous data transmission and is used to access objects without mapping them to an I/O (PDO) connection. With SDO communication, the user will have access to all CANopen objects in the module.
- PDO (Process Data Object)
The PDO object is used for I/O communication.
- Error Signalling
Error register and error history (pre-defined error field) are accessible via 1001 and 1003 objects, respectively. The error code is accessible via 603F object.

◆ DSP402 State Machine

The state machine of the inverter is described in the CANopen DSP402 specification.

■ CANopen DSP402 State Diagram

At any time the Powerlink option card will be in one of the following states. The events that are able to trigger a transition between the states are either sent with the control word or triggered by an internal action. All the possible events and the corresponding transition number are listed in [Table 8](#).

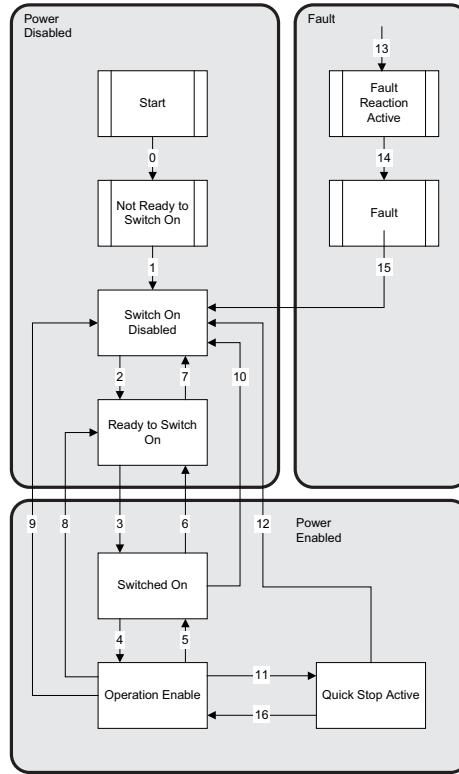

Figure 11 DSP402 State Diagram

Transition 16 is only available while the drive is performing the quick stop action. When completed, transition will automatically be processed.

■ CANopen DS402 State Transition Definition

The YASKAWA Powerlink option must be in the state Operation Enable in order to accept frequency and operation commands. In [Table 14](#) the events needed to change between different states are described. Some events are internally triggered, but most of the events are triggered from the control word received from the bus.

■ CANopen DSP402 Event Description

The following state transitions are available in the CANopen DSP402 drive profile. Transition 0 and 1 are triggered at start-up and when all start-up tests are performed the module will be in state 3. Some commands like fault reset can be triggered from more than one place. For example, the reset command can be triggered both from the bus with the control word, or from the application drive.

Table 8 Event description table

State Transition Number	Transition Name	DSP402 Event
0	Startup => Not Ready To Switch On	Reset
1	Not ready to switch on => Switch on disabled	Self-test and init successful
2	Switch on disabled => Ready to switch on	Shutdown command received
3	Ready to switch on => Switched on disabled	Switch on command received
4	Switched on => Operation enabled	Enable operation command received
5	Operation enabled => Switched on	Disable operation command received
6	Switched on => Ready to switch on	Shutdown command received
7	Ready to switch on => Switch on disabled	Quickstop command received
8	Operation enabled => Ready to switch on	Shutdown command received
9	Operation enabled => Switch on disabled	Disable voltage command received
10	Switched on => Switch on disable	Disable voltage or quickstop command received
11	Operation enabled => Quick stop active	Quickstop command received
12	Quick stop active => Switch on disabled	Quickstop completed or Disable voltage command received
13	All states => Fault reaction active	Fatal fault has occurred in the drive
14	Fault reaction active => Fault	The fault action is completed
15	Fault => Switch on disabled	Fault reset command received
16	Quick stop active => Operation enabled	Enable operation command received

■ **CANopen DSP402 Control Word/Status Word**

This section describes how to control the drive via control word/status word and how to access drive parameters.

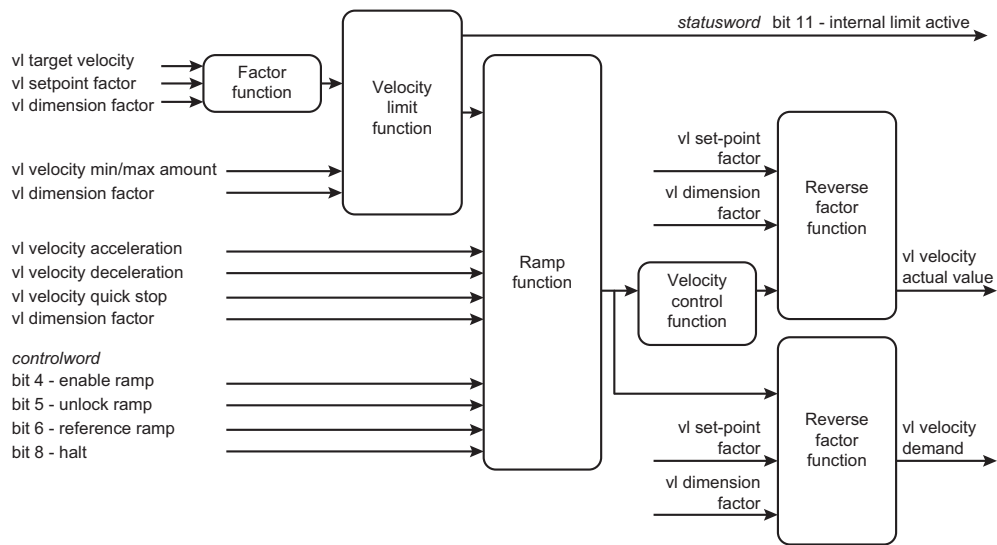

Note: The bits 4 - Enable Ramp, 5 - Unlock Ramp and 6 - Reference Ramp must be set.

Table 9 Control Word

Bit Number	Control Word	Application Reference/CPI Function Calls
0 - 3, 7	-	These bits control the DS402 state machine - See Table 13
4 - 6	Operation mode specific	Please see Table 11 for more details
8 - 15	Reserved	NA

Table 10 Status Word

Bit Number	Status Word	Inverter Reference
0 - 6	-	These bits control the DS402 state machine - See Table 14
7	Warning	1: Warning is present. 0: No warning is present.
8	Manufacturer specific	NA
9	Remote	1: Inverter uses NET cmd or ref 0: Inverter does not use NET cmd or ref
10	Target reached (Op mode spec)	See Table 12
11 - 15	Reserved	NA

Control Word Operation Mode Specific Bits in Velocity Mode

Table 11 Control Word Operation Mode Specific Bits in Velocity Mode

Bit Number	Control Word
4	RFG enable
5	RFG unlock
6	RFG use ref

Status Word Operation Mode Specific Bits in Velocity Mode

Table 12 Status Word Operation Mode Specific Bits in Velocity Mode

Bit Number	Status Word
10	Target reached

CANopen DSP402 Control Word State Transition Bits

Table 13 Control Word State Transitions

DSP402 Command	Bits of the Control Word					Transitions
	Bit 7	Bit 3	Bit 2	Bit 1	Bit 0	
0: Shutdown	0	X	1	1	0	2,6,8
1: Switch on	0	0	1	1	1	3
2: Switch on + enable operation	0	1	1	1	1	3 + 4 (NOTE 1)
3: Disable voltage	0	X	X	0	X	7,9,10,12
4: Quick stop	0	X	0	1	X	7,10,11
5: Disable operation	0	0	1	1	1	5
6: Enable operation	0	1	1	1	1	4,16
7: Fault reset	0 -> 1	X	X	X	X	15

Notes: 1. Automatic transition to Enable operation state after executing SWITCHED ON state functionality.

CANopen DSP402 Status Word State Transition Bits

After a change in the control word (remote control) according to [Table 12](#) the node state will change and the state result will be indicated in the status word according to [Table 13](#).

Table 14 Status Word State Transitions

DSP402 State	Bits of the status word					
	Bit 6	Bit 5	Bit 3	Bit 2	Bit 1	Bit 0
1: Not ready to switch on	0	X	0	0	0	0
2: Switch on disabled	1	X	0	0	0	0
3: Ready to switch on	0	1	0	0	0	1
4: Switched on	0	1	0	0	1	1
5: Operation enabled	0	1	0	1	1	1
6: Quick stop active	0	0	0	1	1	1
7: Fault reaction active	0	X	1	1	1	1
8: Fault	0	X	1	0	0	0

8 Object Dictionary

◆ Object Dictionary Overview

The Object Dictionary consists of three sections:

- Communication Profile Objects
- Manufacturer Specific Profile Objects
- Drive and Motion Profile Objects

The tables below give an overview of the communication objects available in the SI-EL3/V option. Refer to the page references given for further details on each object.

■ Communication Profile Objects (DSP 301)

Index (Hex)	Name	Page
1000	Device Type	20
1001	Error Register	20
1003	Pre-defined Error Field	21
1006	NMT Cycle Time	21
1008	Manufacturer Device Name	21
1009	Manufacturer Hardware Version	21
100A	Manufacturer Software Version	21
1018	Identity Object	21
1020	Device Local Configuration Date and Time	21
1030	Network Interface Parameters	22
1300	SDO Sequence Layer Timeout	22
1400	Receive PDO Communication Parameters	22
1600 - 1628	Receive PDO Mapping	22
1800	Receive PDO Communication Parameters	22
1A00	Transmit PDO mapping	22
1C0B	Loss of SoC	23
1C0D	Loss of PReq	23
1C0F	CRC Error	23
1C14	Loss of SoC Tolerance Interval	23
1F82	Feature Flags	23
1F83	EPL Version	23
1F8C	NMT Current State	23
1F93	EPL Node ID	23
1F98	NMT Cycle Timing	23
1F99	Basic Ethernet Timeout	24

■ Manufacturer Specific Profile Objects (DS 301)

Index (Hex)	Content	Page	
Input	2000	Operation Command	24
	2010	Speed Command	24
	2020	Torque Limit	24
	2030	Torque Compensation	24
	2040	MEMOBUS/Modbus Read Command	25
	2050	MEMOBUS/Modbus Write Command	25
	2060	MEMOBUS/Modbus Unlimited Enter Command	25
	2070	MEMOBUS/Modbus Limited Enter Command	25
	2080	Selectable (default: none)	25
	2090	Selectable (default: none)	25
	20A0	Selectable (default: none)	25
	20B0	Selectable (default: none)	25
	20C0	Selectable (default: none)	25
	20D0	FM analog output 1	26
	20F0	Multi-function DO output	26
	3000	Selectable (default: none)	25
3100	Selectable (default: none)	25	

	Index (Hex)	Content	Page
Output	2100	Drive Status	26
	2110	Output Frequency	26
	2120	Output Current	27
	2130	Output Torque	27
	2140	MEMOBUS/Modbus Read Command Response	27
	2150	MEMOBUS/Modbus Write Command Response	27
	2155	PDO Parameter Write Response	27
	2160	MEMOBUS/Modbus Not Limited Enter Command Response	27
	2180	Selectable (default: Input terminal status)	28
	2190	Selectable (default: Analog input 1 monitor)	28
	21A0	Selectable (default: none)	28
	21B0	Selectable (default: none)	28
	21C0	Selectable (default: none)	28
	21D0	Selectable (default: none)	28
	21E0	Selectable (default: none)	28
	21F0	Selectable (default: none)	28
	2200	Motor Speed	28
	2210	DC Bus Voltage	28
	2220	Analog input monitor A1	28
	2240	Analog input monitor A2	28
2270	Inverter DI Input	29	
4000	Option NVS FATAL Record	29	
4001	Option Info + Status Record	29	

■ Drive and Motion Profile Objects (DSP 402)

Object Type	Index (Hex)	Name	Page
Common Entries	60FD	Digital Inputs	32
	60FE	Digital Outputs	32
Device Control	603F	Error Code	30
	6040	Controlword	30
	6041	Statusword	30
	6060	Modes of operation	31
	6061	Modes of operation display	32
Velocity Mode	6042	v1 target velocity	30
	6043	v1 velocity demand	30
	6044	v1 control effort	30
	6046	v1 velocity min max amount	30
	6048	v1 velocity acceleration	31
	6049	v1 velocity deceleration	31
	604A	v1 velocity quick stop	31
	604C	v1 dimension factor	31
	604D	v1 pole number	31

◆ Communication Profile Objects (DS 301)

■ 1000 (Hex) - Device Type

This object describes the type of the device and its functionality. It is composed of a 16 bit field that describes the device profile used and a second 16 bit field that gives additional information about optional functionality.

Bit 0-15: Device Profile Number = 0x0192 (402) (static)

Bit 16-23: Type = x01 (static)

Bit 24-31: Mode Bits (Vendor specific) = 0x00

Index (Hex)	Subindex	Content	Access	PDO Mapping	Value Range
1000	-	Device type	Read Only	No	Unsigned 32

■ 1001 (Hex) - Error Register

This register shows the fault status of the device. If any errors occurs in the device bit, 0 (generic error) is set to one.

0x00 = No error

0x01 = Generic error

Index (Hex)	Subindex	Content	Access	PDO Mapping	Value Range
1001	-	Error register	Read Only	Tx	Unsigned 8

■ 1003 (Hex) - Pre-defined Error Field

This register provides a history of errors that occurred in the drive and have been signaled via the Emergency object. Subindex 0 contains the number of errors. Subindexes 1 to FF contain a rolling list of error codes where subindex 1 always contains the last occurring error. *Refer to Powerlink Option Card Error Codes on page 37* for a list of possible error codes. The number of valid logged errors in sub index is 0x01-0xFE. Writing a 0 to subindex 0 resets the error field.

Index (Hex)	Subindex	Content	Access	PDO Mapping	Value Range
1003	0	Number of errors	Read/Write	No	Unsigned 8
	1	Standard error field	Read Only		Unsigned 32

■ 1006 (Hex) - NMT Cycle Time

This object contains the Powerlink communication cycle time interval.

Index (Hex)	Subindex	Content	Access	PDO Mapping	Value Range
1006	-	NMT Cycle Time	Read/Write	No	Unsigned 32

■ 1008 (Hex) - Manufacturer Device Name

This object contains the manufacturer device name. String: Powerlink for 1000 series.

Index (Hex)	Subindex	Content	Access	PDO Mapping	Value Range
1008	-	Manufacturer device name	Read Only	No	Visible string

■ 1009 (Hex) - Manufacturer Hardware Version

This object contains the manufacturer hardware version.

Value: 1.x

x = HW revision assigned during production

Index (Hex)	Subindex	Content	Access	PDO Mapping	Value Range
1009	-	Manufacturer hardware version	Read Only	No	Visible string

■ 100A (Hex) - Manufacturer Software Version

This object contains the Manufacturer software version.

Value: VST92x101

Note: The complete Software Version is available via 1018 (Hex), subindex 3. *Refer to 1018 (Hex) - Identity Object on page 21* for details.

Index (Hex)	Subindex	Content	Access	PDO Mapping	Value Range
100A	-	Manufacturer software version	Read Only	No	Visible string

■ 1018 (Hex) - Identity Object

This object contains general information about the drive.

Index (Hex)	Subindex	Content	Access	PDO Mapping	Value	Value Range
1018	-	Identity object	Read/Write	-		Unsigned 32
	0	Number of entries	Read Only	No	4	Unsigned 8
	1	YASKAWA ETG Member Vendor ID	Read Only	No	0x010000E7 (Yaskawa Electric)	Unsigned 32
	2	Powerlink option product code	Read Only	No	0x53454C33 (ASCII: SEL3)	Unsigned 32
	3	YASKAWA Powerlink option software revision number	Read Only	No	9243.xxyy	Unsigned 32
	4	Powerlink option serial number	Read Only	No		Unsigned 32

■ 1020 (Hex) - Device Local Configuration Date and Time

This object contains configuration information about the drive.

Index (Hex)	Subindex	Content	Access	PDO Mapping	Value	Value Range
1020	-	Device local configuration date and time	-	-		-
	0	Number of entries	Read Only	No	2	Unsigned 8
	1	Configuration Date in Days	Read/Write	No		Unsigned 32
	2	Configuration Time in ms	Read/Write	No		Unsigned 32

■ 1030 (Hex) - Network Interface Parameters

This object contains the parameters for the network interface of the drive.

Index (Hex)	Subindex	Content	Access	PDO Mapping	Value	Value Range
1030	-	Network interface parameters	-	-		-
	0	Number of Entries	Read Only	No	9	Unsigned 8
	1	Interface Index	Read Only	No		Unsigned 16
	2	Interface Description	Read Only	No	YEU POWERLINK for 1000 series 1.x	Visible String
	3	Interface Type	Read Only	No	6 (ethernet-csmacd)	Unsigned 8
	4	Interface MTU	Read Only	No		Unsigned 16
	5	Interface Physical Address Note: The MAC address is available via 4001 (Hex) in subindex 6. <i>Refer to 4001 (Hex) - Option Info + Status Record on page 29</i> for details.	Read Only	No		Octet string
	6	Interface Name	Read Only	No		Visible String
	7	Interface Operational State	Read Only	No		Unsigned 8
	8	Interface Administration State	Read/Write	No		Unsigned 8
9	Valid	Read/Write	No		Boolean	

■ 1300 (Hex) - SDO Sequence Layer Timeout

Index (Hex)	Subindex	Content	Access	PDO Mapping	Value Range
1300	-	SDO Sequence Layer Timeout	Read/Write	No	Unsigned 32

■ 1400 (Hex) - Receive PDO Communication Parameters

Index (Hex)	Subindex	Content	Access	PDO Mapping	Value Range
1400	-	Receive PDO communication parameters	-	-	-
	0	Number of Entries	Read Only	No	Unsigned 8
	1	Node ID	Read/Write	No	Unsigned 8
	2	Mapping Version	Read/Write	No	Unsigned 8

■ 1600 (Hex) to 1628 (Hex) - Receive PDO mapping

Index (Hex)	Subindex	Content	Access	PDO Mapping	Value	Value Range
1600	-	Receive PDO mapping	-	-		-
	0	Number of mapped application objects (0-8(2)) For default configurations per RxPDO please refer to section 3.9.1. Max Sub-index: 0x1600: 8 0x1601-0x1628: 2 Note: Write access to those objects are only allowed in the Powerlink pre-operational state.	Read/Write	No	0-8 (Depends on RxPDO)	Unsigned 8
	1	Mapped Object #1	Read/Write	No		Unsigned 32
	2	Mapped Object #2	Read/Write	No		Unsigned 32
	3	Mapped Object #3	Read/Write	No		Unsigned 32
	n	Mapped Object #n	Read/Write	No		Unsigned 32

■ 1800 (Hex) - Receive PDO Communication Parameters

Index (Hex)	Subindex	Content	Access	PDO Mapping	Value	Value Range
1800	-	Receive PDO communication parameters	-	-		-
	0	Number of Entries	Read Only	No	2	Unsigned 8
	1	Node ID	Read/Write	No		Unsigned 8
	2	Mapping Version	Read/Write	No		Unsigned 8

■ 1A00 (Hex) - Transmit PDO Mapping

Index (Hex)	Subindex	Content	Access	PDO Mapping	Value	Value Range
1A00	-	Transmit PDO mapping	-	-		-
	0	Number of mapped application objects (0-16) Note: Write access to those objects are only allowed in the Powerlink pre-operational state.	Read/Write	No	0-16 (Depends on TxPDO)	Unsigned 8
	1	Mapped Object #1	Read/Write	No		Unsigned 32
	2	Mapped Object #2	Read/Write	No		Unsigned 32
	3	Mapped Object #3	Read/Write	No		Unsigned 32
	n	Mapped Object #n	Read/Write	No		Unsigned 32

■ 1C0B (Hex) - Loss of SoC

Index (Hex)	Subindex	Content	Access	PDO Mapping	Value	Value Range
1C0B	-	Loss of SoC	-	-	-	-
	0	Number of Entries	Read Only	No	3	Unsigned 8
	1	Cumulative Counter	Read/Write	No		Unsigned 32
	2	Threshold Counter	Read Only	No		Unsigned 32
	3	Threshold	Read/Write	No		Unsigned 32

■ 1C0D (Hex) - Loss of PReq

Index (Hex)	Subindex	Content	Access	PDO Mapping	Value	Value Range
1C0D	-	Loss of PReq	-	-	-	-
	0	Number of Entries	Read Only	No	3	Unsigned 8
	1	Cumulative Counter	Read/Write	No		Unsigned 32
	2	Threshold Counter	Read Only	No		Unsigned 32
	3	Threshold	Read/Write	No		Unsigned 32

■ 1C0F (Hex) - CRC Error

Index (Hex)	Subindex	Content	Access	PDO Mapping	Value	Value Range
1C0D	-	CRC Error	-	-	-	-
	0	Number of Entries	Read Only	No	3	Unsigned 8
	1	Cumulative Counter	Read/Write	No		Unsigned 32
	2	Threshold Counter	Read Only	No		Unsigned 32
	3	Threshold	Read/Write	No		Unsigned 32

■ 1C14 (Hex) - Loss of SoC Tolerance Interval

Index (Hex)	Subindex	Content	Access	PDO Mapping	Value Range
1C14		Loss of SoC Tolerance Interval	Read/Write	No	Unsigned 32

■ 1F82 (Hex) - Feature Flags

Index (Hex)	Subindex	Content	Access	PDO Mapping	Value Range
1F82		Feature Flags	Read Only	No	Unsigned 32

■ 1F83 (Hex) - EPL Version

Index (Hex)	Subindex	Content	Access	PDO Mapping	Value Range
1F83		Loss of SoC Tolerance Interval	Read Only	No	Unsigned 8

■ 1F8C (Hex) - NMT Current State

Index (Hex)	Subindex	Content	Access	PDO Mapping	Value Range
1F8C		NMT Current State	Read Only	Tx	Unsigned 8

■ 1F93 (Hex) - EPL Node ID

Index (Hex)	Subindex	Content	Access	PDO Mapping	Value	Value Range
1F93	-	EPL Node ID	-	-	-	-
	0	Number of entries	Read Only	No	2	Unsigned 8
	1	Node ID	Read Only	No		Unsigned 6
	2	Node ID by HW	Read Only	No		Boolean

■ 1F98 (Hex) - NMT Cycle Timing

Index (Hex)	Subindex	Content	Access	PDO Mapping	Value	Value Range
1F98	-	NMT Cycling Timing	-	-	-	-
	0	Number of entries	Read Only	No	8	Unsigned 8
	1	Isochronous Tx max payload	Read Only	No		Unsigned 16
	2	Isochronous Rx max payload	Read Only	No		Unsigned 16
	3	PRes max latency	Read Only	No		Unsigned 32
	4	PReq actual payload limit	Read/Write	No		Unsigned 16
	5	PRes actual payload limit	Read/Write	No		Unsigned 16
	6	ASnd max latency	Read Only	No		Unsigned 32
	7	Multiplexed cycle count	Read/Write	No		Unsigned 8
	8	Asynchronous MTU	Read/Write	No		Unsigned 16

8 Object Dictionary

■ 1F99 (Hex) - Basic Ethernet Timeout

Index (Hex)	Subindex	Content	Access	PDO Mapping	Value Range
1F99		Basic Ethernet Timeout	Read/Write	Tx	Unsigned 32

◆ Manufacturer Specific Profile Objects (DS 301)

The SI-EL3/V option offers the manufacturer specific objects listed below. These objects are specific to Yaskawa products and are therefore not available on other Powerlink products.

The manufacturer specific objects list consists of objects that have predefined, non-changeable content and objects that are configurable. The content of configurable objects can be determined by linking these objects to drive parameters, monitors or MEMOBUS/Modbus registers (refer to *Selectable Object Content on page 33*).

Input objects are processed in a cycle of 2 ms. Output objects are, depending on the object, updated in a cycle of either 2 ms or 8 ms. The update cycle cannot be changed.

■ 2000 (Hex) - Operation Command

This object is used for starting and stopping the drive, for controlling the multi-function digital input terminals, as well for triggering and resetting faults.

Index (Hex)	Subindex	Content	Access	PDO Mapping	Value	Data Length
2000	0	Operation Command	Read/Write	Possible		2 byte
	1	Value	Read/Write	Rx/Tx		
	2	MEMOBUS/Modbus register address	Read Only	No	Run operation signal	

Bit No. (Hex)	Description	Function
0	Forward Run	1: Forward run, 0: Stop (Enabled when b1-02=3)
1	Reverse Run	1: Reverse run, 0: Stop (Enabled when b1-02=3)
2	External Fault (EF0)	1: External Fault Input (EF0)
3	Fault Reset	1: Fault Reset
4	Terminal S1 Function	Multi-Function Input: H1-01
5	Terminal S2 Function	Multi-Function Input: H1-02
6	Terminal S3 Function	Multi-Function Input: H1-03
7	Terminal S4 Function	Multi-Function Input: H1-04
8	Terminal S5 Function	Multi-Function Input: H1-05
9	Terminal S6 Function	Multi-Function Input: H1-06
10 to 15	Not used	Not used

■ 2010 (Hex) - Speed Reference/Speed Limit

Sets the speed reference or speed limit. The unit of this value depends on the setting of the drive parameter o1-03 (0 = Hz; 1 = % with 100% equals parameter E1-04; 2 = rev/min with the motor poles number entered into E2-04/E4-04/E5-04; 3 = user defined parameters o1-10 and 01-11. The value will be used as the speed reference for speed control (d5-01 = 0) or as the speed limit in torque control (d5-01 = 1).

Note: The availability of the torque control function depends on the drive and the selected control mode. For details refer to the technical manual for the drive.

Index (Hex)	Subindex	Content	Access	PDO Mapping	Value	Data Length
2010	0	Number of entries	Read/Write	Possible		2 byte
	1	Value	Read/Write	Rx/Tx	Frequency reference	-
	2	MEMOBUS/Modbus register address	Read Only	No		-

■ 2020 (Hex) - Torque Reference/Torque Limit

This object sets the torque reference or the torque limit in units of 0.1%.

In order to use this object set drive parameter F6-06 to 1. The value will be used as the torque reference for torque control (d5-01 = 1) or as the torque limit in speed control (d5-01 = 0).

Note: The availability of the torque control and torque limit function depends on the drive and the selected control mode. For details refer to the technical manual for the drive.

Index (Hex)	Subindex	Content	Access	PDO Mapping	Value	Data Length
2020	0	Number of entries	Read/Write	Possible		2 byte
	1	Value	Read/Write	Rx Tx	Torque ref/limit	-
	2	MEMOBUS/Modbus register address	Read Only	No		-

■ 2030 (Hex) - Torque Compensation

This object sets the torque compensation in units of 0.1%.

Index (Hex)	Subindex	Content	Access	PDO Mapping	Value	Data Length
2030	0	Torque Compensation	Read/Write	Possible		2 byte
	1	Value	Read/Write	Rx Tx	Torque compensation	-
	2	MEMOBUS/Modbus register address	Read Only	No		-

■ 2040 (Hex) - MEMOBUS/Modbus Read Request

This object can be used to read out the content of drive MEMOBUS/Modbus registers. The address of the MEMOBUS/Modbus must be written in byte 3 and 4 of Subindex 1, bytes 1 and 2 have to be set to 0. After sending a MEMOBUS/Modbus Read Request to the drive, the MEMOBUS/Modbus register content can be read out from object 2140H.

For more details on MEMOBUS/Modbus address and data, refer to the MEMOBUS/Modbus/Modbus Data Table in Appendix C of the technical manual for the drive.

Index (Hex)	Subindex	Content	Access	PDO Mapping	Data Length
2040	0	Number of entries	Read Only	Possible	1 byte
	1	MEMOBUS/Modbus read request	Read/Write		2 + 2 byte MEMOBUS/Modbus 0000H + Address

■ 2050 (Hex) - MEMOBUS/Modbus Write Request

Using this object, drive MEMOBUS/Modbus registers can be written. The data must be written in byte 1 and 2 of Subindex 1, the MEMOBUS/Modbus address must be written in bytes 3 and 4. After sending a MEMOBUS/Modbus Write Request to the drive, the response can be read from object 2150H.

For more details on MEMOBUS/Modbus address and data, refer to the MEMOBUS/Modbus Data Table in Appendix C of the technical manual for the drive.

Index (Hex.)	Subindex	Content	Access	PDO Mapping	Data Length
2050	0	Number of entries	Read Only	Possible	1 byte
	1	MEMOBUS/Modbus Write request	Read/Write		2 + 2 byte MEMOBUS/Modbus Data + Address

■ 2060 (Hex) - MEMOBUS/Modbus Unlimited ENTER Command

Depending on the drive parameter H5-11 setting, an ENTER command must be used to activate drive parameters changed via MEMOBUS/Modbus Write Commands. The Unlimited ENTER command activates parameters in the drive RAM only. If the drive power is cycled, parameter changes are lost. If more than one parameter has been changed, it is enough to send only one ENTER command after the last parameter change. Doing so will activate all changed parameters. This ENTER command can be used without limitations.

To execute this type of ENTER command, “save” (73H + 61H + 76H + 65H) has to be written in object 2060H, subindex 0.

Index (Hex)	Subindex	Content	Access	PDO Mapping	Data Length
2060	0	Unlimited ENTER command	Read/Write	Possible	4 byte

■ 2070 (Hex) - MEMOBUS/Modbus Limited ENTER Command

Depending on the drive parameter H5-11 setting, an ENTER command must be used to activate drive parameters changed via MEMOBUS/Modbus Write Commands. The limited ENTER command activates parameters in the drive’s RAM and saves them to the EEPROM. When power supply loss occurs or the power supply is cycled, the drive will operate using the saved parameters. If more than one parameter has been changed, it is sufficient to send only one ENTER command after the last parameter change. Doing so will activate all changed parameters. This type of ENTER command can be applied approximately 100,000 times and should be used only when necessary.

To execute this type of ENTER command, “save” (73H + 61H + 76H + 65H) has to be written in object 2070H, subindex 0.

Note: Write access to this object is only allowed in the Powerlink pre-operational state.

Index (Hex)	Subindex	Content	Access	PDO Mapping	Data Length
2070	0	Limited enter command	Read/Write	Possible	4 byte

■ 2080 to 3100 (Hex) - Freely Configurable Input Objects

The content of these objects can be freely selected by linking them to drive MEMOBUS/Modbus registers. Refer to [Selecting the Object Content on page 33](#) for details.

Index (Hex)	Subindex	Content	Default	Access	PDO Mapping	Value	Data Length
2080 <I>	0	Number of entries	2	Read Only	No		1 Byte
	1	Value of mapped MEMOBUS register. AAAA = MEMOBUS register 1 value BBBB = MEMOBUS register 2 value	-	Read/Write	Possible	0xAAAABBBB	4 byte
	2	MEMOBUS/Modbus register address of content 1 and 2 AAAA = MEMOBUS register 1 address BBBB = MEMOBUS register 2 address Reg. value=0xFFFF ' Mapping disabled. Note: Those values can only be changed in Powerlink pre-operational state. Refer to Table 4 for the state relations.	FFFF (Hex)/FFFF (Hex)	Read/Write <I>	No	0xAAAABBBB	4 Byte
2090 to 20C0, 3000, and 3100	0	Number of entries	2	Read Only	No		1 Byte
	1	Value of mapped MEMOBUS register. AAAA = MEMOBUS register value	-	Read/Write	Possible	0xAAAA	2 Byte
	2	MEMOBUS/Modbus register address of content AAAA = MEMOBUS register address. Note: Those values can only be changed in Powerlink pre-operational state. Refer to Table 4 for the state relations.	FFFF (Hex)	Read/Write <I>	No	0xAAAA	2 Byte

<I> Read/Write access when SI-EL3/V is in the Pre-Operational state, Read only access if the SI-EL3/V is in the Operational state or if the drive is running.

8 Object Dictionary

■ 20D0 (Hex) - FM analog output 1

This object controls the FM analog output value.

Index (Hex.)	Subindex	Content	Access	PDO Mapping	Data Length
20D0	1	Value	Read/Write	Rx Tx	-
	2	MEMOBUS/Modbus register address	Read Only	No	-

■ 20E0 (Hex) - AM analog output 2

This object controls the AM analog output value.

Index (Hex.)	Subindex	Content	Access	PDO Mapping	Data Length
20E0	1	Value	Read/Write	Rx Tx	-
	2	MEMOBUS/Modbus register address	Read Only	No	-

■ 20F0 (Hex) - Multi-function DO output

This object controls the multi-function DO outputs.

Index (Hex.)	Subindex	Content	Access	PDO Mapping	Data Length
20F0	1	Value	Read/Write	Rx Tx	-
	2	MEMOBUS/Modbus register address	Read Only	No	-

■ 2100 (Hex)/2101 (Hex) - Drive Status

These objects can be used to monitor the drive status. The value in object 2100 (Hex) is not filtered.

Index (Hex)	Subindex	Content	Default	Access	PDO Mapping	Data Length	Update Cycle
2100	0	Number of entries	-	Read Only	Possible	2 byte	2 ms
	1	Value	-	Read Only	Tx	2 byte	2 ms
	2	MEMOBUS/Modbus register address	00FC (Hex)	Read Only	No	2 byte	-

Bit No. (Hex)	Function	Description
0	During Run	1: During Run 0: During Stop
1	During Zero Speed	1: During Zero Speed
2	Reverse Running	1: During Reverse Running 0: During Forward Running
3	During Fault Reset Signal Input	1: During Fault Reset Signal Input
4	During Speed Agree	1: During Speed Agree
5	During Drive Ready	1: During Drive Ready 0: Not Ready
6	During Alarm	1: During Alarm
7	During Fault	1: During Fault
8	During Operation Error	1: During Operation Error
9	During Momentary Power Loss	1: During Momentary Power Loss 0: During Power Loss
A	NetCtrl Status	1: NetCtrl
B	Digital Output 1 Status (function set in drive parameter H2-01)	1: ON 0: OFF
C	Digital Output 2 Status (function set in drive parameter H2-02)	1: ON 0: OFF
D	Digital Output 3 Status (function set in drive parameter H2-03)	1: ON 0: OFF
E	Motor 2 Selected	1: Motor 2 Selected

■ 2110 (Hex) - Output Frequency

This object can be used to monitor the drive output frequency. The unit of the monitor value is determined by drive parameter o1-03 (0 = Hz; 1 = % with 100% equals parameter E1-04; 2 = rev/min with the motor poles number entered into E2-04/E4/04/E5-04; 3 = user defined parameters o1-10 and 01-11).

The value will be used as the speed reference for speed control (d5-01 = 0) or as the speed limit in torque control (d5-01 = 1).

Index (Hex)	Subindex	Content	Default	Access	PDO Mapping	Data Length	Update Cycle
2110	0	Number of entries	-	Read Only	-	-	-
	1	Value	-	Read Only	Tx	Unsigned 16	-
	2	MEMOBUS/Modbus register address	0041 (Hex)	Read Only	No	Unsigned 16	-

■ 2120 (Hex) - Output Current

This object can be used to monitor the drive output current in units of Ampere. The current value resolution is the same as in drive monitor U1-03 (for details refer to the technical manual of the drive).

Index (Hex)	Subindex	Content	Default	Access	PDO Mapping	Value Range
2120	0	Number of entries	-	Read Only	-	-
	1	Value	-	Read Only	Tx	Unsigned 16
	2	MEMOBUS/Modbus register address	00FB (Hex)	Read Only	No	Unsigned 16

■ 2130 (Hex) - Output Torque Reference

This object can be used to monitor the output torque reference. The availability of this object content depends on the drive control mode. If the selected control mode does not support this monitor (equal to drive monitor U1-09), the torque reference monitor value will be 0. Refer to the drive technical manual for details.

Index (Hex)	Subindex	Content	Default	Access	PDO Mapping	Value Range
2130	0	Number of entries	-	Read Only	-	-
	1	Value	-	Read Only	Tx	Unsigned 16
	2	MEMOBUS/Modbus register address	0048 (Hex)	Read Only	No	Unsigned 16

■ 2140 (Hex) - MEMOBUS/Modbus Read Response

This object contains the data of the drive MEMOBUS/Modbus register specified in object 2040 (Hex). Bytes 1 and 2 of subindex 1 will contain the data, bytes 3 and 4 will contain the MEMOBUS/Modbus Address read.

0xAAAABBBB ->

0xAAAA = drive register

0xB BBBB = Data

Index (Hex)	Subindex	Content	Access	PDO Mapping	Value Range
2140	0	Number of entries	Read Only	No	Unsigned 8
	1	MEMOBUS/Modbus read response	Read Only	Tx	Unsigned 32

■ 2150 (Hex) - MEMOBUS/Modbus Write Response

This object contains the response from the drive when writing a drive parameter using a MEMOBUS/Modbus write command (object 2050 (Hex)). Bytes 1 and 2 of subindex 1 will contain the data that were written, bytes 3 and 4 will contain the MEMOBUS/Modbus Address that was written to.

0xAAAABBBB ->

0xAAAA = drive register

0xB BBBB = Data

Index (Hex)	Subindex	Content	Access	PDO Mapping	Value Range
2150	0	Number of entries	Read Only	No	Unsigned 8
	1	MEMOBUS write response		Tx	Unsigned 32

■ 2155 (Hex) - PDO Parameter Write Response

Note: Object only available in Powerlink SAFE_OP or OPERATIONAL state. Object data is always cleared when a transition from PRE_OP 'SAFE_OP is done.

This object contains the response from the drive when writing a drive parameter directly using a RxPDO. Byte 1 and 2 contain the last RxPDO number that caused the error. Byte 3 contains the number of errors. The error counter is increased when an NOID Online-DRV control data write is flagged as invalid by the drive. This object can only be read if the communication option is in Operational state.

Index (Hex)	Subindex	Content	Access	PDO Mapping	Data Length
2155	0	PDO Parameter Write Response	Read Only	Tx	3 byte

■ 2160 (Hex) - MEMOBUS/Modbus Not Limited Enter Command Response

This object contains the response from the drive when writing an Enter command using object 2060 (Hex).

Response values:

OK: 0x65766173

ERR: MEMOBUS error code or SDO abort code if SDO request.

Index (Hex)	Subindex	Content	Access	PDO Mapping	Data Length
2160	0	MEMOBUS/Modbus not limited enter command response	Read Only	Tx	4 byte

8 Object Dictionary

■ 2180 (Hex) to 21E0 (Hex) - Configurable Output Objects

Note: This value can only be changed in Powerlink pre-operational state.

The content of these objects can be selected by linking them to drive MEMOBUS/Modbus registers.

Index (Hex)	Subindex	Content	Default	Access	PDO Mapping	Data Length
2180 to 21E0	0	Number of entries	-	Read Only	No	Unsigned 8
	1	Value of mapped drive register	-	Read Only	Tx	Unsigned 16
	2	MEMOBUS/Modbus register address of content	Defaults: 0x2180: 0x0049 (Input Terminal Status) 0x2190: 0x004E (Analog Input A1 Monitor) 0x21A0-0x21E0: Default: 0xFFFF (No mapping)	Read/Write	No	Unsigned 16

■ 21F0 (Hex) - Configurable Output Object

Note: This value can only be changed in Powerlink pre-operational state.

The content of this object can be selected by linking them to drive MEMOBUS/Modbus registers.

Index (Hex)	Subindex	Content	Content	Access	PDO Mapping	Data Length
21F0	0	Number of entries	-	Read Only	No	Unsigned 8
	1	Value of mapped drive register 1 and 2	Value: 0xAAAABBBB ' AAAA = MEMOBUS register 1 address BBBB = MEMOBUS register 2 address	Read Only	Tx	Unsigned 32
	2	MEMOBUS register address of content 1 and 2	Value: 0xAAAABBBB ' AAAA = MEMOBUS register 1 address BBBB = MEMOBUS register 2 address Reg. value=0xFFFF ' Mapping disabled. Default: 0xFFFFFFFF	Read/Write	No	Unsigned 32

■ 2200 (Hex) - Motor Speed

This object can be used to monitor the motor speed. The value in object 2200 (Hex) is not filtered. Setting units are determined by o1-03.

The availability of the object content depends on the drive control mode. If the selected control mode does not support this monitor (equal to drive monitor U1-05), the object value will be 0. Refer to the drive technical manual for details.

Index (Hex)	Subindex	Content	Default	Access	PDO Mapping	Data Length
2200	0	Number of Entries	-	Read Only	No	Unsigned 8
	1	Motor Speed	-	Read Only	Tx	Unsigned 16
	2	MEMOBUS/Modbus register address of content	0044 (Hex)	Read Only	No	Unsigned 16

■ 2210 (Hex) - DC Bus voltage

This object can be used to monitor the DC BUS voltage.

Index (Hex)	Subindex	Content	Default	Access	PDO Mapping	Data Length
2210	0	Number of entries	-	Read Only	-	-
	1	Value	1 V	Read Only	Tx	Unsigned 16
	2	MEMOBUS/Modbus register address of content	0046 (Hex)	Read Only	No	Unsigned 16

■ 2220 (Hex) - Analog Input Monitor A1

This object can be used to display the analog input A1 level: 100% when input is 10 V.

Index (Hex)	Subindex	Content	Default	Access	PDO Mapping	Data Length
2220	0	Number of entries	-	Read Only	-	-
	1	Value	0.1 %	Read Only	Tx	Unsigned 16
	2	MEMOBUS/Modbus register address of content	004E (Hex)	Read Only	No	Unsigned 16

■ 2240 (Hex) - Analog Input Monitor A2

This object can be used to display the analog input A2 level: 100% when input is 10 V.

Index (Hex)	Subindex	Content	Default	Access	PDO Mapping	Data Length
2240	0	Number of entries	-	Read Only	-	-
	1	Value	0.1 %	Read Only	Tx	Unsigned 16
	2	MEMOBUS/Modbus register address of content	004F (Hex)	Read Only	No	Unsigned 16

■ 2260 (Hex) - Analog Input Monitor A3

This object can be used to display the analog input A3 level: 100% when input is 10 V.

Index (Hex)	Subindex	Content	Default	Access	PDO Mapping	Data Length
2260	0	Number of entries	-	Read Only	-	-
	1	Value	0.1 %	Read Only	Tx	Unsigned 16
	2	MEMOBUS/Modbus register address of content	0050 (Hex)	Read Only	No	Unsigned 16

■ 2270 (Hex) - Drive DI Input

This object can be used to display the input terminal status.

Index (Hex)	Subindex	Content	Default	Access	PDO Mapping	Data Length
2270	0	Number of entries	-	Read Only	-	-
	1	Value	-	Read Only	Tx	Unsigned 16
	2	MEMOBUS/Modbus register address of content	0049 (Hex)	Read Only	No	Unsigned 16

■ 4000 (Hex) - Option NVS FATAL Record

Internal FATAL NVS record for debugging purposes.

Note: Writing 0xFB to sub-index 0 will clear the record in NVS memory.

Index (Hex)	Subindex	Content	Default	Access	PDO Mapping	Data Length
4000	-	Information regarding a system failure/crash is stored in this object and can be read out for on-site troubleshooting.	-	Read/Write	No	Unsigned 8
	1	Total number of FATAL events logged since entry was cleared.	-	Read Only	No	Unsigned 32
	2	Boot firmware revision in flash when the last event was logged.	-	Read Only	No	Unsigned 16
	3	Application firmware revision in flash when the last event was logged	-	Read Only	No	Unsigned 32
	4	Option internal enumerated status code of the logged event.	-	Read Only	No	Unsigned 16
	5	Event specific parameter value associated with the status event.	-	Read Only	No	Unsigned 16
	6	NOI System active error bits when event occurred.	-	Read Only	No	Unsigned 16
	7	NOI System latched (All errors that have occurred since start-up) error bits.	-	Read Only	No	Unsigned 16
	8	INV status word when the last error was logged.	-	Read Only	No	Unsigned 16
	9	Last error logged in object 0x603F.	-	Read Only	No	Unsigned 16
	10	Event number parameter associated with FATAL event.	-	Read Only	No	Unsigned 32
	11	Total running time in milliseconds of option system since power-up to the FATAL event was triggered.	-	Read Only	No	Unsigned 32
	12	Internal system Task ID enumeration that causes the FATAL event.	-	Read Only	No	Unsigned 16
	13	Line in source-code file where the FATAL event was triggered.	-	Read Only	No	Unsigned 16
	14	Name of source-code file where the FATAL event was triggered.	-	Read Only	No	Visible String

■ 4001 (Hex) - Option Info + Status Record

Provides general information of option system firmware parts and internal system states.

Index (Hex)	Subindex	Content	Default	Access	PDO Mapping	Data Length
4001	0	Provides general information of option system firmware parts and internal system states.	-	Read Only	No	Unsigned 8
	1	Boot firmware revision in flash. Value: 0x00AABBCC AA = Major revision BB = Minor revision CC = Build	-	Read Only	No	Unsigned 32
	2	Application firmware revision in flash. Value: 0x00AABBCC AA = Major revision BB = Minor revision CC = Build	-	Read Only	No	Unsigned 32
	3	Total running time in milliseconds of option system since power-up.	-	Read Only	No	Unsigned 32
	4	NOI System active error bits.	-	Read Only	No	Unsigned 16
	5	NOI System latched (All errors that have occurred since start-up) error bits.	-	Read Only	No	Unsigned 16
	6	MAC address assigned during manufacturing.	-	Read Only	No	Octet string

◆ Drive and Motion Profile Objects (DSP 402)

The drive supports the Drive and Motion Profile DSP 402 Velocity Mode. Before using the Velocity Mode objects the following parameters have to be set up in the drive:

- The number of motor poles must be set to E2-04.
- The frequency reference and output frequency display unit must be set to r/min by setting parameter o1-03 = 2.

If these settings are not done properly, the Velocity Mode objects can not be used or the drive might not operate as expected.

Note: Drive and Motion Control (DSP 402) cannot be set or referenced unless o1-03 = 2.

■ 603F (Hex) - Errorcode

This object shows the errorcode in case an error has occurred.

Index (Hex)	Subindex	Content	Access	PDO Mapping	Value Range
603F	0	Errorcode	Read Only	Tx	0...65535

■ 6040 (Hex) - Controlword

This object sets the device to different states.

Index (Hex)	Subindex	Content	Access	PDO Mapping	Value Range
6040	0	Controlword	Read/Write	Rx/Tx	0...65535

■ 6041 (Hex) - Statusword

This object shows different states of the device.

Index (Hex)	Subindex	Content	Access	PDO Mapping	Value Range
6041	0	Statusword	Read Only	Tx	0...65535

■ 6042 (Hex) - v1 Target Velocity

This object sets the speed reference. It is internally multiplies with the v1 dimension factor (604C). Prior to using the object, drive parameter o1-03 has to be set to min⁻¹.

Index (Hex)	Subindex	Content	Access	PDO Mapping	Value Range	Unit
6042	0	v1 target velocity	Read/Write	Rx/Tx	-32768...0...32767	r/min

■ 6043 (Hex) - v1 Velocity Demand

The v1 Velocity Demand is the speed reference provided by the ramp function and limiting functions in units of min⁻¹.

Index (Hex)	Subindex	Content	Access	PDO Mapping	Value Range	Unit
6043	0	v1 velocity demand	Read Only	Tx	-32768...0...32767	r/min

■ 6044 (Hex) - v1 Velocity Control Effort/Actual Value

The v1 Velocity Control Effort is the output frequency of the drive to the motor. The unit is min⁻¹. In case of close loop vector control mode the motor speed can be read out.

Index (Hex)	Subindex	Content	Access	PDO Mapping	Value Range	Unit
6044	0	v1 control effort	Read Only	Tx	-32768...0...32767	r/min

■ 6046 (Hex) - v1 Velocity Min Max Amount

This object provides two subindexes to set the minimum and maximum speed reference in r/min.

Index (Hex)	Subindex	Content	Access	PDO Mapping	Value Range	Unit
6046	1	v1 velocity min amount Minimum speed reference allowed d2-02 (Frequency reference lower limit) Note: The parameter specifies the % rate of E1-04 maximum output frequency. Internal parameter calculations needed.	Read/Write	Rx/Tx	0...(2 ³² -1)	r/min
	2	v1 velocity max amount Maximum speed reference allowed d2-01 (Frequency reference upper limit) Note: The parameter specifies the % rate of E1-04 maximum output frequency. Internal parameter calculations needed.	Read/Write	Rx/Tx	0...(2 ³² -1)	r/min

■ 6048 (Hex) - vI Velocity Acceleration

The vI velocity acceleration specifies the acceleration time. The quotient of the subindexes delta speed and delta time determines the acceleration time. The object values correspond to the acceleration time setting in the drive.

Index (Hex)	Subindex	Content	Access	PDO Mapping	Value Range	Unit
6048	1	Acceleration Delta speed	Read/Write	Rx/Tx	0...(2 ²³ - 1)	r/min
	2	Acceleration Delta time	Read/Write	Rx/Tx	0...65535	sec

■ 6049 (Hex) - vI Velocity Deceleration

The vI velocity min max amount specifies the deceleration time. The quotient of the subindexes delta speed and delta time determines the deceleration time. The object values correspond to the deceleration time setting in the drive.

Index (Hex)	Subindex	Content	Access	PDO Mapping	Value Range	Unit
6049	1	Deceleration Delta speed	Read/Write	Rx/Tx	0...(2 ²³ - 1)	r/min
	2	Deceleration Delta time	Read/Write	Rx/Tx	0...65535	sec

■ 604A Hex) - vI Velocity Quick Stop

The vI velocity quick stop specifies the quick stop ramp. The quotient of the subindexes delta speed and delta time determines the quick stop ramp time. The object values correspond to the fast stop time setting in the drive.

Index (Hex)	Subindex	Content	Access	PDO Mapping	Value Range	Unit
604A	1	Quick Stop Delta speed	Read/Write	Rx/Tx	0...(2 ²³ - 1)	r/min
	2	Quick Stop Delta time	Read/Write	Rx/Tx	0...65535	sec

■ 604C (Hex) - vI Dimension Factor

The vI dimension factor is multiplied with the target velocity. The quotient of the subindexes vI dimension factor numerator and vI dimension factor denominator determines the vI dimension factor.

Default Value = 1

This parameter affects other objects such as:

0x6042 vI_target_velocity,

0x6043 vI_velocity_demand.

0x6044 vI_control_effort

0x6046 vI_velocity_min_max_amount.

0x6048 vI_velocity_acceleration

0x6049 vI_velocity_deceleration

0x604A vI_velocity_quick_stop.

and is always used in a product (multiplication).

Index (Hex)	Subindex	Content	Access	PDO Mapping	Value Range
604C	1	vI dimension factor numerator Internal in Powerlink option card, save in NVS memory. Default Value = 1.	Read/Write	Rx/Tx	-2 ³¹ ...(2 ³¹ -1)
	2	vI dimension factor denominator Internal in Powerlink option card, save in NVS memory. Default Value = 1.	Read/Write	Rx/Tx	-2 ³¹ ...(2 ³¹ -1)

■ 604D (Hex) - vI Pole Number

The vI pole number sets the number of motor poles and is used to calculate all speed related values in r/min. This value corresponds to the number of motor poles setting in the drive.

E2-04 (Number of motor poles)

Index (Hex)	Subindex	Content	Access	PDO Mapping	Value Range
604D	0	vI pole number	Read/Write	Tx	0...255

■ 6060 (Hex) - Modes of Operation

This object sets the mode of the device.

Value: 2: Velocity mode.

Value: -2: Vendor control mode.

Index (Hex)	Subindex	Content	Access	PDO Mapping	Value Range
6060	0	Modes of Operation	Read/Write	Rx/Tx	-128...127

8 Object Dictionary

■ 6061 (Hex) - Modes of Operation Display

This object shows the mode of the device.

Value: 2: Velocity mode.

Value: -2: Vendor control mode.

Index (Hex)	Subindex	Content	Access	PDO Mapping	Value Range
6061	0	Modes of Operation Display	Read Only	Tx	-128...127

■ 60FD (Hex) - Digital Inputs

This object contains the drive digital output status (seen as input to the network).

The content of this object is equal to drive MEMOBUS/Modbus register 004A (Hex) (drive output terminal status monitor U1-11) and depends on the drive the SI-EL3/V option card is used with. For details on the content of this register refer to the technical manual for the drive.

Bit defines:

0-15 = reserved (Set to zero)

16-31 = U1-11 (Output terminal status)

Index (Hex)	Subindex	Content	Access	PDO Mapping	Value Range
60FD	0	Drive digital input status	Read Only	Tx	0...(2 ³² -1)

Bit No. (Hex)	Function	Description
0 to F	Reserved	
10 to 1F	Bit 0 to F of drive register 004A (Hex) (drive output terminal status monitor U1-11)	1: ON 0: OFF

■ 60FE (Hex) - Digital Outputs

This object is used to set drive digital inputs (seen as output from the network).

Index (Hex)	Subindex	Content	Access	PDO Mapping	Value Range
60FE	0	Number of elements	Read Only	-	0...255
	1	Physical Outputs	Read/Write	Rx/Tx	0...(2 ³² -1)

Bit No. (Hex)	Function	Description
0 to 17	Reserved (Set to zero)	
18	Terminal S3 Function	1=set, 0=clear
19	Terminal S4 Function	1=set, 0=clear
20	Terminal S5 Function	1=set, 0=clear
21	Terminal S6 Function	1=set, 0=clear
22 to 23	Reserved (Set to zero)	
24	External Fault (EF0)	1=set, 0=clear
25	Fault Reset	1=set, 0=clear
26 to 31	Reserved (Set to zero)	

9 Configuring Manufacturer Specific CANopen Objects

This section describes the configuration of manufacturer specific objects that support content selection.

◆ Selectable Object Content

All parameters, monitors and other control registers in the drive are represented by their MEMOBUS/Modbus register. The Powerlink option card allows the user to select the content of some manufacturer specific objects by mapping them to any of the drives MEMOBUS registers, so that those objects can be set up to contain the value of drive parameters, monitors as well as other MEMOBUS/Modbus registers (e.g. alarm and fault status, etc.). Refer to the drive Technical Manual for details on available MEMOBUS/Modbus registers.

■ Selecting the Object Content

Objects with selectable content have the following structure.

Object Type	Subindex	Content	Access	PDO Mapping	Data Length
2 Byte	0	Number of entries	Read Only	No	1 byte
	1	Data	depends on object	Possible	2 byte
	2	MEMOBUS/Modbus register address	Read/Write </>	No	2 byte
4 Byte	0	Number of entries	Read Only	No	1 byte
	1	Data	depends on object	Possible	4 byte
	2	MEMOBUS/Modbus register address 1 and 2	Read/Write </>	No	4 byte

</> Read/Write access when SI-EL3/V is in the Pre-Operational state, Read only access if the SI-EL3/V is in the Operational state or if the drive is running.

To map the content of a certain MEMOBUS/Modbus register of the drive to subindex 1 of an object, the MEMOBUS/Modbus register address must be written to subindex 2 of the object.

Examples

- In order to map the drive output power monitor (U1-08, 0047 (Hex)) to output object 21A0 (Hex), write 0047 (Hex) to subindex 2 of object 21A0 (Hex).
- In order to map the speed reference 1 (d1-01, 0280 (Hex)) to input object 2090 (Hex), write 0280 (Hex) to subindex 2 of object 2090 (Hex).
- In order to map the input terminal status (U1-10, 0049 (Hex)) and output terminal status (U1-11, 004A (Hex)) to output object 21F0 (Hex) (4 Byte), write 0049 (Hex) to the higher and 004A (Hex) to the lower word of object 2090 (Hex), subindex 2.

■ Limitations of Object Content Selection

The following limitations have to be considered when setting the content of an object.

- The object content can only be changed when the SI-EL3/V option card is in Pre-Operational state and drive is stopped (Run command not active).
- When object content selection is ongoing, no other request or command, including Run, should be sent to the drive. Otherwise, an error message or an emergency message (code 6301 (Hex)) will be sent.
- For 4 byte input objects, MEMOBUS/Modbus register numbers below 0100 (Hex) can be linked in any combination. If MEMOBUS/Modbus register numbers above 00FF (Hex) are linked to a 4 byte object, the MEMOBUS/Modbus register numbers must be consecutive.

Mapped Register 1	Mapped Register 2	
0007 (Hex)	0009 (Hex)	Possible
0201 (Hex)	0202 (Hex)	Possible
0201 (Hex)	0203 (Hex)	Not possible
0200 (Hex)	FFFF (Hex) (Disable)	Possible
FFFF (Hex) (Disable)	0200 (Hex)	Possible

- Register numbers must not be consecutive for 4 Byte output objects.
- A MEMOBUS/Modbus register can no be mapped to two or more objects at the same time.
- MEMOBUS/Modbus registers 0001 (Hex), 0002 (Hex), 0004 (Hex), 0005 (Hex), 0007 (Hex), 0008 (Hex), 0009 (Hex), and 0014 (Hex) are already linked to not changeable input objects and can not be linked to any object with selectable content. Trying to map one of those registers to an input object will result in an error message.

10 Process Data Objects (PDO)

PDOs (Process Data Object) will be used for I/O exchange. PDOs are mapped to objects during configuration (PRE-OPERATIONAL state). TxPDOs are used to transfer data from the option card and RxPDOs are used to transfer data to the option card. The module supports at 16 parameters mapped to RxPDO and 16 parameters mapped to TxPDO.

◆ PDOs and Default PDO Setup

The drive supports 15 Receive and 16 Transmit PDOs. The tables below show available PDOs, their default settings and the objects required to set up when changing the PDO configuration or the PDO mapping.

■ Transmit PDOs (TxPDO)

The Transmit PDOs have a default mapping according to the table below. The transmit PDOs can be re-mapped by the end user by writing to map objects 0x1A00-0x1A28, please see *Communication Profile Objects (DSP 301) on page 19*.

PDO number	Transmit PDO Mapping	
	Mapped objects (Hex)	Index (Hex)
1	Sub-index 1: 0x6041#0, 2-bytes (DSP402 status word)	0x1A00
2	Sub-index 1: 0x6041#0, 2-bytes (DSP402 status word) Sub-index 2: 0x6061#0, 2-bytes, (DSP402 Modes of operation display)	0x1A01
6	Sub-index 1: 0x6041#0, 2-bytes (DSP402 status word) Sub-index 2: 0x6044#0, 2-bytes, (v1 control effort)	0x1A05
7	Sub-index 1: 0x6041#0, 2-bytes (DSP402 status word) Sub-index 2: 0x60FD#0, 4-bytes, (Digital inputs)	0x1A06
21	Sub-index 1: 0x6042#0, 2-bytes (v1 target velocity)	0x1A14
22	Sub-index 1: 0x6043#0, 2-bytes (v1 velocity demand)	0x1A15
23	Sub-index 1: 0x6048#1, 4-bytes (v1 Accel delta speed) Sub-index 2: 0x6048#2, 2-bytes, (v1 Accel delta time)	0x1A16
24	Sub-index 1: 0x6049#1, 4-bytes (v1 Decel delta speed) Sub-index 2: 0x6049#2, 2-bytes, (v1 Decel delta time)	0x1A17
25	Sub-index 1: 0x604A#1, 4-bytes (v1 quick-stop delta speed) Sub-index 2: 0x604A#2, 2-bytes, (v1 quick-stop delta time)	0x1A18
26	Sub-index 1: 0x604C#1, 4-bytes (v1 Dimension factor) Sub-index 2: 0x604C#2, 4-bytes, (v1 Dimension factor)	0x1A19
36	Sub-index 1: 0x2100#1, 2-bytes (Drive status)	0x1A23
37	Sub-index 1: 0x2110#1, 2-bytes (Output frequency)	0x1A24
38	Sub-index 1: 0x2120#1, 2-bytes (Output current)	0x1A25
39	Sub-index 1: 0x2130#1, 2-bytes (Output torque reference)	0x1A26
40	Sub-index 1: 0x2140#1, 2-bytes (MEMOBUS/Modbus read response)	0x1A27
41	Sub-index 1: 0x2150#1, 2-bytes (MEMOBUS/Modbus write response)	0x1A28

■ Receive PDOs (RxPDO)

The Receive PDOs have a default mapping according to the table below. The end user can re-map Receive PDOs by writing to the map objects 0x1600-1628, refer to *Communication Profile Objects (DSP 301) on page 19*.

PDO number	Receive PDO Mapping	
	Mapped objects (Hex)	Index (Hex)
1	Sub-index 1: 0x6040#0, 2-bytes (DSP402 control word)	0x1600
2	Sub-index 1: 0x6040#0, 2-bytes (DSP402 control word) Sub-index 2: 0x6060#0, 1-bytes, (DSP402 Modes of operation)	0x1601
6	Sub-index 1: 0x6040#0, 2-bytes (DSP402 control word) Sub-index 2: 0x6042#0, 2-bytes, (v1 target velocity)	0x1605
7	Sub-index 1: 0x6040#0, 2-bytes (DSP402 control word) Sub-index 2: 0x60FE#1, 4-bytes, (Physical digital outputs)	0x1606
8	Sub-index 1: 0x6040#0, 2-bytes (DSP402 control word) Sub-index 2: 0x6060#0, 1-bytes, (DSP402 Modes of operation)	0x1607
21	Sub-index 1: 0x6048#1, 4-bytes (v1 Accel delta speed) Sub-index 2: 0x6048#2, 2-bytes, (v1 Accel delta time)	0x1614
22	Sub-index 1: 0x6049#1, 4-bytes (v1 Decel delta speed) Sub-index 2: 0x6049#2, 2-bytes, (v1 Decel delta time)	0x1615
23	Sub-index 1: 0x604A#1, 4-bytes (v1 quick-stop delta speed) Sub-index 2: 0x604A#2, 2-bytes, (v1 quick-stop delta time)	0x1616
24	Sub-index 1: 0x604C#1, 4-bytes (v1 Dimension factor) Sub-index 2: 0x604C#2, 4-bytes, (v1 Dimension factor)	0x1617
36	Sub-index 1: 0x2000#1, 2-bytes (Operation command)	0x1623
37	Sub-index 1: 0x2010#1, 2-bytes (Speed reference/limit)	0x1624
38	Sub-index 1: 0x2020#1, 2-bytes (Torque reference/limit)	0x1625
39	Sub-index 1: 0x2030#1, 2-bytes (Torque compensation)	0x1626
40	Sub-index 1: 0x2040#1, 4-bytes (MEMOBUS/Modbus read request)	0x1627
41	Sub-index 1: 0x2050#1, 4-bytes (MEMOBUS/Modbus write request)	0x1628

■ RxPDO Mapped Drive Registers Above 0x0100 Range

Drive registers above 0x0100 cannot be configured as process data exchanged on each interface scan cycle. To be able to RxPDO map those objects on Powerlink the drive registers above 0x0100 are refreshed every 8 ms, the drive registers below 0x0100 are refreshed every 2 ms. The drive registers above 0x0100 are using the overlaid MEMOBUS/Modbus channel in interface to write the drive registers required.

ENTER command management for drive registers above 0x0100 control sets:

- New value only written against drive if it changes from the previously written value.
- If a value update is detected the write will be scheduled directly after the RxPDO Powerlink process data cycle is complete.
- If the written value via MEMOBUS/Modbus failed for some reason, i.e. Parameter cannot be written when the drive is running, a new retry will be triggered after 8 ms.
- If a RAM ENTER command is required for the written value to be used by the drive, the ENTER command will be written when the last register that should be updated in an slow IO data scan set update is triggered.
 - E.g. mapped drive registers: A: 0x0200, B: 0x0201, C: 0x0203
 - All three registers change at the same time:
RAM ENTER command executed with C.
 - Only register 0x0200 changes
RAM ENTER command executed with A.

11 Drive Parameter, Monitor and Control Register Access

All drive parameters, monitors, and other control registers are represented by their MEMOBUS/Modbus register. The registers can be read or written by accessing these registers through the SI-EL3/V option card.

MEMOBUS/Modbus registers can be directly read or written using MEMOBUS/Modbus read/write commands. The registers can also be mapped to the content of a manufacturer specific object and then be accessed by reading from or writing to this object. Refer to *Selecting the Object Content on page 33* for details on object content selection.

When writing drive parameters, certain precautions concerning message timing must be taken into account.

- The drive requires a certain time to activate changes to parameter values. When changing multiple parameters, make sure to add a wait time between write requests.
- If an Enter command is issued, make sure to add a wait time between the Enter command and the next message.

Refer to the drive technical manual for information about MEMOBUS/Modbus addresses available in the drive and the wait times required between parameter write requests and Enter commands.

◆ Drive Parameter and Monitor Access by MEMOBUS/Modbus Read/Write Commands

■ Reading a Drive Register, Parameter or Monitor

Reading a drive parameter, monitor or control register using a MEMOBUS/Modbus read command requires the following steps:

- Write the address of the drive MEMOBUS/Modbus register to be read to subindex 0 of object 2040 (Hex).
- Read the value of the drive MEMOBUS/Modbus register from the MEMOBUS/Modbus read response in subindex 1 of object 2140 (Hex).

Objects 2040 (Hex) and 2140 (Hex) can both be mapped to PDOs.

■ Writing a Parameter or Drive Control Register

Writing to drive parameters or control registers can be performed following the steps below:

- Write the value and the MEMOBUS/Modbus address of the drive parameter or control register to subindex 1 of object 2050 (Hex).
- Read the MEMOBUS/Modbus write response from subindex 1 of object 2150 (Hex) in order to verify that the item is written correctly.

If drive parameters are written and parameter H5-11 in the drive is set to 0, additionally a RAM Enter command (object 2060 (hex)) must be issued in order let the change take effect. To store the parameter change in the non-volatile memory of the drive, a ROM Enter command (object 2070 (hex)) must be issued instead. An Enter command can be issued by performing the steps below.

- Write "save" (73H + 61H + 76H + 65H) to subindex 1 of object 2060 (Hex) for a RAM Enter command, or to subindex 1 of object 2070 (Hex) for a ROM Enter command.
- When using a RAM Enter command, read the Enter command response from object 2160 (hex) in order to verify the Enter command is performed successfully.

Note: When multiple drive parameters are changed, only one Enter command is required after the last parameter value to activate all parameter changes.

Objects 2050/01 (Hex), 2060 (Hex), 2070 (Hex), 2150/01 (Hex) and 2160 (Hex) can be mapped to PDOs.

◆ Initializing the Drive

The drive can be initialized by writing the corresponding initialization code to Modbus/MEMOBUS register 0103 (object 1011 hex) (drive parameter A1-03; refer to the technical manual of the drive for details on initialization codes). The initialization is performed only if drive parameter H5-11 is set to "0" and if an Unlimited Enter Command is sent after setting register 0103 (object 1011 hex).

In order to initialize a drive via Powerlink communications follow the instructions below:

1. Read out the value of drive parameter H5-11 using a Modbus/MEMOBUS Read Request (Obj. 2040 (hex)) on drive register 04C3 (hex) (H5-11).
2. If the content of register 04C3 (hex) is "1" then change it to "0" using a Modbus/MEMOBUS Write Request (Obj. 2050 (hex)).
3. Set drive parameter A1-03 to the desired initialization mode. For example, in order to perform a "2-Wire Initialization", write "08AC" (hex) (2220) to Modbus/MEMOBUS register 0103 (object 1011 hex).
4. Finish the initialization by sending an Unlimited Enter Command (Obj. 2070 (Hex)).

12 Fault Diagnosis and Possible Solutions

◆ Powerlink Option Card Error Codes

The following error codes will be shown in object 1003, subindex 01 if the correspondent error occurred on the drive.

■ Inverter and Powerlink Faults

■ Emergency Object (EMCY)

The emergency object is used for sending fault information from the communication module to the CANopen/Powerlink network.

The emergency object is triggered by a fault event from the host or the option card itself. An emergency object is transmitted only once per 'error event'.

Emergency error codes are specified for a number of events. Emergency word specification:

Table 15 Emergency Word Specification

Byte	0	1	2	3	4	5	6	7
Content	Emergency error code	Error register object 0x1001	Manufacturer specific error info. Not used. Set to zero.					

■ Emergency Messages, DSP301 & DSP402

The error codes specified in the list below can be read from CANopen object 0x1003 (Pre-defined error field)

Table 16 Error Codes

Error Code (Hex)	Meaning	Drive Display	INVR:0x0080 Enum Value
0000	No error	No error	0x00
3220	DC bus undervoltage	Uv1	0x02
5200	Control power supply undervoltage	Uv2	0x03
3221	DC bus charging circuit fault	Uv3	0x04
2330	Ground fault	GF	0x06
2220	Over current	oC	0x07
3210	DC bus overvoltage	ov	0x08
4280	Heatsink overheat	oH	0x09
4210	Heatsink overheat	oH1	0x0A
2310	Motor overload	oL1	0x0B
2221	Drive overload	oL2	0x0C
2311	Overtorque detection 1	oL3	0x0D
2312	Overtorque detection 2	oL4	0x0E
5420	Braking transistor fault	rr	0x0F
4410	Internal braking resistor overheat	rH	0x10
5441	External fault 3	EF3	0x11
5442	External fault 4	EF4	0x12
5443	External fault 5	EF5	0x13
5444	External fault 6	EF6	0x14
FF17	Cooling FAN fault	FAn	0x17
7180	Motor over speed (control mode using PG)	oS	0x18
8321	Speed deviation (control mode using PG)	dEv	0x19
7305	PG fault (control mode using PG)	PGo	0x1A
3130	Input phase loss	PF	0x1B
3300	Output phase loss	LF	0x1C
FF01	Motor overheat alarm	oH3	0x1D
5300	Digital operator disconnected	oPr	0x1E
5530	EEPROM error	Err	0x1F
FF08	MEMOBUS/Modbus Error	CE	0x21
FF07	BUS error	bUS	0x22
FF06	Control fault	CF	0x25
5481	Fault input from option card	EF0	0x27
FF02	PID feedback lost	FbL	0x28
FF03	Undertorque detected 1	UL3	0x29
FF04	Undertorque detected 2	UL4	0x2A
FF05	High slip braking OL	oL7	0x2B
FF31	Intermediary voltage fault	VCF	0x31
FF36	Output current imbalance	LF2	0x36
FF3B	Too many speed search restarts	SEr	0x3B
FF41	PID feedback loss	FbH	0x41
FF0D	External fault at input terminal S1	EF1	0x42
FF0E	External fault at input terminal S2	EF2	0x43
FF44	Mechanical weakening detection 1	oL5	0x44
FF45	Mechanical weakening detection 2	UL5	0x45

12 Fault Diagnosis and Possible Solutions

Error Code (Hex)	Meaning	Drive Display	INVR:0x0080 Enum Value
FF46	Current offset fault	CoF	0x46
FF47	Programming Error 1	PE1	0x47
FF49	Current offset fault	dWFL	0x49
6301	Error during object content selection	-	-

◆ SDO Abort Codes

SDO abort codes are supported as specified in DS301. Additionally the abort codes listed below are implemented.

Table 17 SDO Abort Codes

SDO Abort Code	Description
0602 0010 (Hex)	Consecutive MEMOBUS/Modbus Read/Write/Enter commands are sent but the wait time between messages is too short.
	A MEMOBUS/Modbus Read or Write Response (2140 (Hex) and 2150 (Hex)) was attempted but no or an incorrect MEMOBUS/Modbus address has been written to object 2040 (Hex) or 2050 (Hex) before.
	A MEMOBUS/Modbus write request has been sent during DC bus under voltage.
0602 0022 (Hex)	Drive Profile DSP402 is used and a value is written to object 6042 (Hex) (v1 Target Velocity) while the drive status is not "Operation Enable".
	Object 2155 (Hex) is tried to be read while the SI-EL3/V option is not in "Operational" state.
	A MEMOBUS/Modbus Read or Write command (2040 (Hex) and 2050 (Hex)) was performed with an invalid MEMOBUS/Modbus address.

◆ Drive-Side Error Codes

Drive-side error codes appear on the drive's digital operator. Causes of the errors and corrective actions are listed in [Table 18](#) and [Table 9](#). For additional error codes, refer to the technical manual for the drive.

The bUS (Powerlink Option Communication Error) and EF0 (External Fault Input from the Powerlink Option) may appear as an alarm or a fault. If they occur as an alarm, the "ALM" LED on the drive digital operator will blink and the alarm code will flash in the display. When these occur as a fault, the "ALM" LED will light and the display will show the fault code.

If communication stops while the drive is running, check the following items:

- Is the Powerlink Option properly installed?
- Is the communication line properly connected to the Powerlink Option? Is it loose?
- Is the controller program working? Has the controller CPU stopped?
- Did a momentary power loss interrupt communications?

■ Faults

[Table 18](#) lists possible faults when using a communication option. The drive's fault contact will close if one of these faults occur.

Table 18 Fault Display and Possible Solutions

Digital Operator Display		Fault Name
bUS	bUS	Powerlink Option Communication Error
		After establishing initial communication, the connection was lost. Only detected when the run command or frequency reference is assigned to the option (b1-01=3 or b1-02=3).
Cause		Possible Solution
Master controller (PLC) has stopped communicating.		Check for faulty wiring.
Communication cable is not connected properly.		Correct any wiring problems.
A data error occurred due to noise.		Check the various options available to minimize the effects of noise. Take steps to counteract noise in the control circuit wiring, main circuit lines, and ground wiring. If a magnetic contactor is identified as a source of noise, install a surge absorber to the contactor coil. Make sure the cable used fulfills the Powerlink requirements. Ground the shield on the controller side and on the Powerlink Option side.
Powerlink Option is damaged.		If there are no problems with the wiring and the error continues to occur, replace the Powerlink Option.
A Powerlink state transition from OP→PRE_OP_1 was made when the drive was in OPERATION enabled.		Check and correct state machine transitions in control word.

Digital Operator Display		Fault Name
EF0	EF0	External Fault Input from Powerlink Option
		The alarm function for an external device has been triggered.
Cause		Possible Solution
An external fault is being sent from the upper controller (PLC).		Remove the cause of the external fault. Reset the external fault input from the upper controller (PLC) device.
Problem with the upper controller (PLC) program.		Check the program used by the upper controller (PLC) and make the appropriate corrections.

Digital Operator Display		Fault Name
oFA00	oFA00	Powerlink Option Card Fault
Cause		Possible Solution
Non-compatible option connected to the drive.		1. Check drive firmware version as described on page 13. 2. If drive firmware version is correct, replace option card. 3. Replace the drive.

Digital Operator Display		Fault Name
oFA01	oFA01	Powerlink Option Card Fault
Cause		Possible Solution
Problem with the connectors between the drive and Powerlink Option.		Turn the power off and check the connectors between the drive and Powerlink Option.

Digital Operator Display		Fault Name
oFA30 and oH32	oFA30 to oFA32	Option card has detected a Communication Option card ID error
Cause		Possible Solution
Drive system is overloaded. Drive is not properly processing the state		Force Powerlink state change to NOT_ACTIVE/BASIC_ETHERNET

Digital Operator Display		Fault Name
oFA30 to oFA43	oFA30 to oFA43	Powerlink Option Card Fault at Connector CN5-A
Cause		Possible Solution
Option card hardware fault		⇒ Replace the Powerlink Option. Contact Yaskawa for assistance.

■ Minor Faults and Alarms

Table 6 lists up alarms that might occur during operation using a communication option board. If a multi function digital output of the drive is programmed for H2-□□ = 10, the output will close if these alarms occur.

Digital Operator Display		Minor Fault Name
CALL	CALL	Serial Communication Transmission Error
Cause		Possible Solution
Communication wiring is faulty, there is a short circuit, or something is not connected properly.		Check for wiring errors. ⇒ Correct the wiring. ⇒ Remove and ground shorts and reconnect loose wires.
Programming error on the master side		⇒ Check communications at start-up and correct programming errors.
Communication circuitry is damaged.		⇒ Replace the drive if the fault continues to occur.

Digital Operator Display		Minor Fault Name
EEP	EEP	EEPROM Error
Cause		Possible Solution
Communication wiring is faulty, there is a short circuit, or something is not connected properly.		Check for wiring errors. ⇒ Correct the wiring. ⇒ Remove and ground shorts and reconnect loose wires.
EEPROM checksum error		If these errors occur, the object dictionary will be reset to its default values. ⇒ After the object dictionary has been changed and object dictionary contents are then changed, execute a Store Parameter command (Index = 1010 (Hex)). ⇒ If the object dictionary has not been changed, execute a Restore Parameter command (Index = 1011 (Hex)).

13 Specifications

◆ Specifications

Table 19 Option Card Specifications

Items	Specifications
Model	SI-EL3/V
Communication Profile	DS 301 Ver. 4.02 DSP 402 Ver. 3.0 Velocity Mode
Connector	RJ45 connector
Communications Speed	10/100 Mbps
Ambient Temperature	-10 °C to +50 °C
Humidity	up to 95% RH (no condensation)
Storage Temperature	-20 °C to +60 °C (allowed for short-term transport of the product)
Area of Use	Indoor (free of corrosive gas, airborne particles, etc.)

◆ Internal Scan Cycle

V1000: 2 ms

◆ Revision History

The revision dates and the numbers of the revised manuals appear on the bottom of the back cover.

MANUAL NO. YEU SIEP C710606 84A

Published in Germany September 2013 13-9
 └─ Date of publication └─ Date of original publication

Date of Publication	Revision Number	Section	Revised Content
September 2013	–	–	First Edition

YASKAWA AC Drive V1000 Option

ETHERNET 

POWERLINK

Technical Manual

DRIVE CENTER (INVERTER PLANT)

2-13-1, Nishimiyaichi, Yukuhashi, Fukuoka, 824-8511, Japan
Phone: 81-930-25-3844 Fax: 81-930-25-4369
<http://www.yaskawa.co.jp>

YASKAWA ELECTRIC CORPORATION

New Pier Takeshiba South Tower, 1-16-1, Kaigan, Minatoku, Tokyo, 105-6891, Japan
Phone: 81-3-5402-4502 Fax: 81-3-5402-4580
<http://www.yaskawa.co.jp>

YASKAWA AMERICA, INC.

2121 Norman Drive South, Waukegan, IL 60085, U.S.A.
Phone: (800) YASKAWA (927-5292) or 1-847-887-7000 Fax: 1-847-887-7310
<http://www.yaskawa.com>

YASKAWA ELÉTRICO DO BRASIL LTDA.

Avenda Fagundes Filho, 620 Bairro Saude, São Paulo, SP04304-000, Brasil
Phone: 55-11-3585-1100 Fax: 55-11-5581-8795
<http://www.yaskawa.com.br>

YASKAWA EUROPE GmbH

Hauptstrasse 185, 65760 Eschborn, Germany
Phone: 49-6196-569-300 Fax: 49-6196-569-398
<http://www.yaskawa.eu.com>

YASKAWA ELECTRIC UK LTD.

1 Hunt Hill Orchardton Woods, Cumbernauld, G68 9LF, United Kingdom
Phone: 44-1236-735000 Fax: 44-1236-458182
<http://www.yaskawa.co.uk>

YASKAWA ELECTRIC KOREA CORPORATION

7F, Doore Bldg. 24, Yeoido-dong, Yeongdungpo-gu, Seoul, 150-877, Korea
Phone: 82-2-784-7844 Fax: 82-2-784-8495
<http://www.yaskawa.co.kr>

YASKAWA ELECTRIC (SINGAPORE) PTE. LTD.

151 Lorong Chuan, #04-01, New Tech Park, 556741, Singapore
Phone: 65-6282-3003 Fax: 65-6289-3003
<http://www.yaskawa.com.sg>

YASKAWA ELECTRIC (SHANGHAI) CO., LTD.

No. 18 Xizang Zhong Road, 17F, Harbour Ring Plaza, Shanghai, 200001, China
Phone: 86-21-5385-2200 Fax: 86-21-5385-3299
<http://www.yaskawa.com.cn>

YASKAWA ELECTRIC (SHANGHAI) CO., LTD. BEIJING OFFICE

Room 1011, Tower W3 Oriental Plaza, No. 1 East Chang An Ave.,
Dong Cheng District, Beijing, 100738, China
Phone: 86-10-8518-4086 Fax: 86-10-8518-4082

YASKAWA ELECTRIC TAIWAN CORPORATION

9F, 16, Nanking E. Rd., Sec. 3, Taipei, 104, Taiwan
Phone: 886-2-2502-5003 Fax: 886-2-2505-1280



YASKAWA EUROPE GMBH

In the event that the end user of this product is to be the military and said product is to be employed in any weapons systems or the manufacture thereof, the export will fall under the relevant regulations as stipulated in the Foreign Exchange and Foreign Trade Regulations. Therefore, be sure to follow all procedures and submit all relevant documentation according to any and all rules, regulations and laws that may apply.

Specifications are subject to change without notice for ongoing product modifications and improvements.

© 2013 YASKAWA EUROPE GMBH. All rights reserved.